

ITEM CODE	CAPACITANCE μF (*)	DIMENSIONS			
		※L	※T	※H	※H ₁
ECWH 10752R () V	0.0075 (752)	18.0	6.0	12.5	34.5
" 10822R () V	0.0082 (822)	"	"	"	"
" 10912R () V	0.0091 (912)	"	"	13.0	35.0
" 10103R () V	0.01 (103)	"	6.5	"	"
" 10113R () V	0.011 (113)	"	"	13.5	35.5
" 10123R () V	0.012 (123)	"	"	"	"
" 10133R () V	0.013 (133)	"	7.0	"	"
" 10153R () V	0.015 (153)	"	"	14.0	36.0
" 10163R () V	0.016 (163)	"	7.5	"	"
" 10183R () V	0.018 (183)	"	"	14.5	36.5
" 10203R () V	0.02 (203)	"	8.0	15.0	37.0
" 10223R () V	0.022 (223)	"	8.5	"	"
" 10243R () V	0.024 (243)	"	"	15.5	37.5
" 10273R () V	0.027 (273)	"	9.0	16.0	38.0
" 10303R () V	0.03 (303)	"	9.5	16.5	38.5
" 10333R () V	0.033 (333)	23.0	7.5	16.0	38.0
" 10363R () V	0.036 (363)	"	"	"	"
" 10393R () V	0.039 (393)	"	8.0	16.5	38.5
" 10433R () V	0.043 (433)	"	8.5	"	"
" 10473R () V	0.047 (473)	"	"	17.0	39.0
" 10513R () V	0.051 (513)	"	9.0	17.5	39.5
" 10563R () V	0.056 (563)	"	9.5	"	"
" 10623R () V	0.062 (623)	"	"	18.0	40.0
" 10683R () V	0.068 (683)	"	10.0	19.0	41.0
" 10753R () V	0.075 (753)	"	10.5	19.5	41.5
" 10823R () V	0.082 (823)	"	11.0	20.0	42.0
" 10913R () V	0.091 (913)	"	11.5	20.5	42.5
" 10104R () V	0.1 (104)	"	12.0	21.0	43.0

ITEM CODE NUMBER STRUCTURE

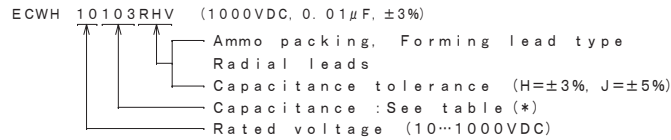

ALTERATION		
ISSUE	DESCRIPTION	DATE
△	Company name changed	Apr. 1 2012
△	Company name changed	Apr. 1 2013
△	Company name changed	Apr. 1 2015
△	Company name changed	Apr. 1 2022
SPECIFICATIONS No.		

CONSTRUCTION

The capacitor is of non-inductive construction, wound with metallized polypropylene film dielectric.
The capacitor is enclosed in non-combustible epoxy resin and has two leads.

MARKING

Marking comprises capacitance, capacitance tolerance, rated voltage, manufacturer's trademark and type name "WHV" and manufacturer's date code.

PROPERTIES

Capacitance : See table at 1kHz
 Capacitance tolerance : ±3% (H), ±5% (J)
 Rated voltage : 1000VDC (Derating of rated voltage by 1.25%/°C at more than 85°C)
 Withstand voltage (terminal-terminal) : DC Rated voltage × 150% for 60s
 (terminal-enclosure) : 1500VAC for 60s
 Insulation resistance : 30,000MΩ or more, at 500VDC, 20°C for 60s
 Dissipation factor : 0.1% or less at 1kHz, 0.2% or less at 10kHz
 Category temperature range : From -40°C to +105°C (including temperature rise on unit surface)

(example)

WHV 103 H

Ⓜ 1.0kVDC

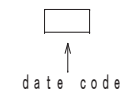

DESIGN	M. MEKADA
CHECKED	H. YAMADA
APPROVAL	T. KATO
ESTABLISHMENT	Mar. 18, 2010
TYPE NAME	ECWH 10***R () V
NAME	METALLIZED POLYPROPYLENE CAPACITOR
DRAWING NAME	PRODUCT DRAWING
DRAWING No.	0022J-J-E (1/2)

Film Capacitor Business Unit
 Device Solutions Business Division
 Panasonic Industry Co., Ltd.

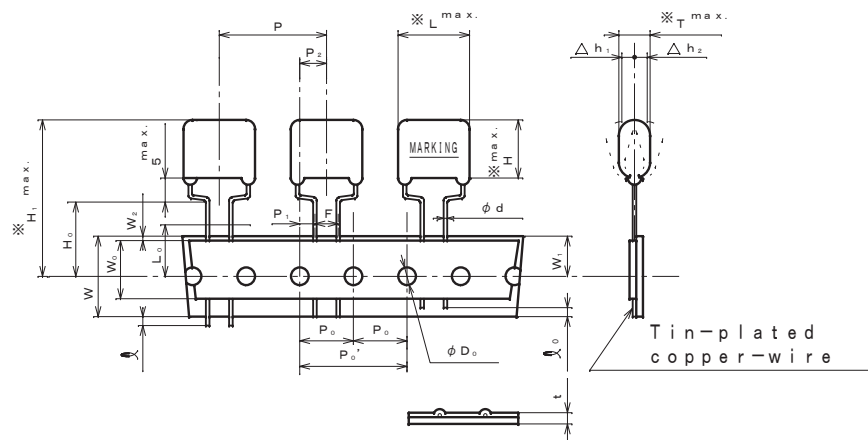

SYMBOL	ITEM	VALUE	TOLERANCE	REMARKS
P	Pitch of component	30.0	±1.0	Tilt of component and curvature of leads shall be included.
P ₀ '	Feed hole pitch	30.0	±0.2	
P ₀	Feed hole pitch	15.0	±0.2	
P ₁	Feed hole center to lead	3.75	±0.5	
P ₂	Hole center to comp. center	7.5	±1.3	Tilt of component due to curvature of leads shall be included.
φd	Lead-wire diameter	0.8	±0.05	
F	Lead-to-lead distance	7.5	±0.2	
Δh _{1,2}	Component alignment	0~2.0		Tilt of component due to curvature of leads shall be included.
W	Paper backing width	18.0	±0.5	
W ₀	Adhesive tape width	12.5	min.	The hold down tape shall not protrude beyond the carrier tape.
W ₁	Hole position	9.0	±0.5	
W ₂	Hold-down tape position	0~3.0		
H ₀	Lead-wire clinch height	16.0	+1.0	
φD	Lead wire protrusion	0	max.	
φD ₀	Lead wire depression	7.0	max.	
φD ₀	Feed hole diameter	4.0	±0.2	
t	Total tape thickness	0.7	±0.2	
L ₀	Length of snapped lead	11.0	max.	

- Note 1. No more than 2 consecutive missing is permitted.
 Note 2. A tape conjunction and a tape discrepancy specify as follows.

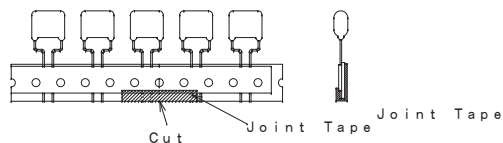

A tape sliding shall not exceed in an allowance of "P₀" dimension.
 A joint tape put on the back side of paper backing, and turn up the lower part to the front.

- Note 3. A tape trailer having at least 3 feed holes is required at the end of the tape.
 Note 4. Marking on components may not be the same side.
 Note 5. The tape adhesion is more than 3.92N (400gf)/25mm.
 Note 6. The lead clinch at the tape, shows as follows.

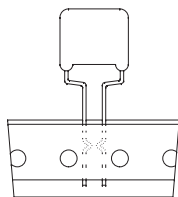

Packing specification

1. Case size (Ammo pack)

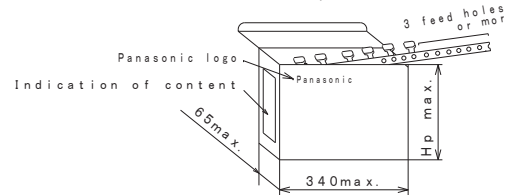

2. Packing quantity

Capacitance range (μF)	Quantity (pcs.)	H p
0.0075~0.018	500	360
0.02 ~0.024	400	"
0.027 ~0.03	300	"
0.033 ~0.047	400	"
0.051 ~0.082	300	"
0.091 ~0.1	"	410

Handling notes

- One package must be packed one product only.
- The storage must be stacked 5 boxes or less. (Surface printed placing upward)
 (For prevention from displacement of capacitors and damage of lead crimping)
- The packing box must be handled with care and never thrown out.

REFERENCE

TYPE NAME	ECWH 10***R () V
DRAWING No.	0022J-J-E (2/2)

Film Capacitor Business Unit
 Device Solutions Business Division
 Panasonic Industry Co., Ltd.