

未量産品 / Under development  
 量産スケジュールについては当社にお問合せ下さい / Please consult Panasonic as for Mass production schedule.  
 As of April, 2020.

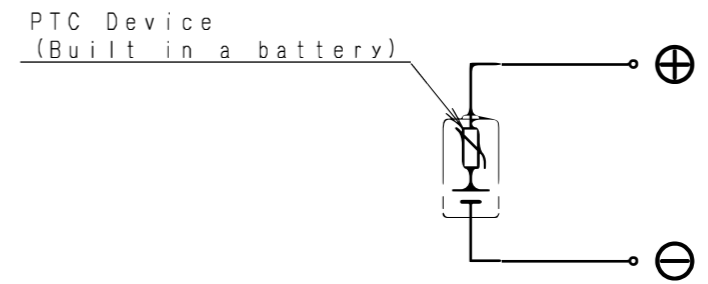
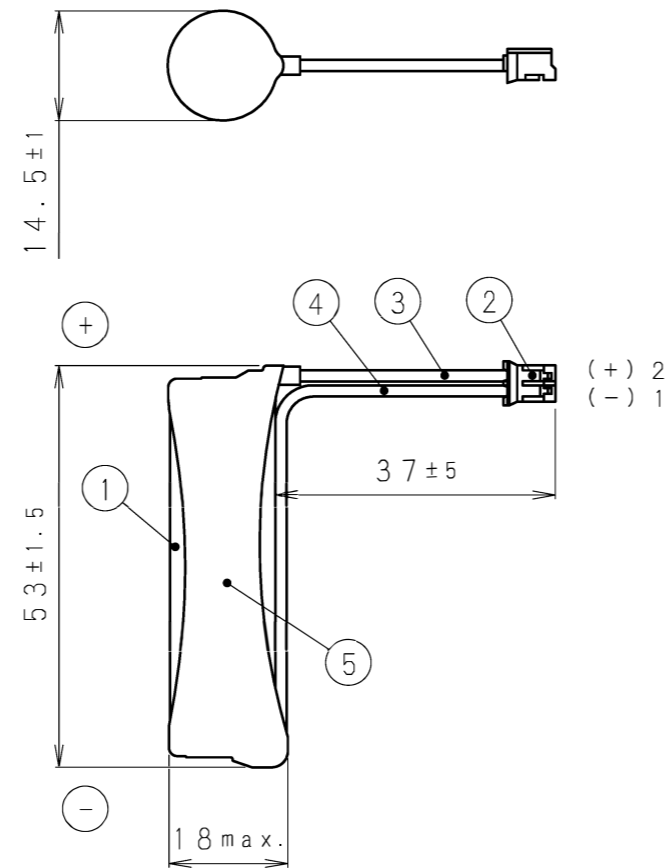

CIRCUIT DIAGRAM  
 [回路図]

No	CONTENTS [内容]	
①	BATTERY [素電池]	CR-AAU : PANASONIC
②	CONNECTOR	JST [日本圧着端子製造]
	HOUSING	PHR-2
	TERMINAL	SPH-002T-P0.5S : TIN PLATING [Snめっき]
③	(+) LEAD WIRE	UL AWM3385 AWG24 : RED
④	(-) LEAD WIRE	UL AWM3385 AWG24 : BLACK
⑤	OUTER TUBE [外装チューブ]	HEAT SHRINKABLE TUBE

NOTE [注記]  
 1. NOMINAL VOLTAGE : 3V [公称電圧 : 3V]  
 2. ( ) : REFERENCE DIMENSION AND ANGLE [ ( ) 寸法、角度は参考値]

PRODUCT NO.	CR-AAUx1P (V)	SCALE	1 : 1
DRAWING NO.	PC-CR-AAUx1P (V)		UNIT : mm