

**未量産品 / Under development**  
**量産スケジュールについては当社にお問合せ下さい / Please consult Panasonic as for Mass production schedule.**  
**As of April, 2020.**

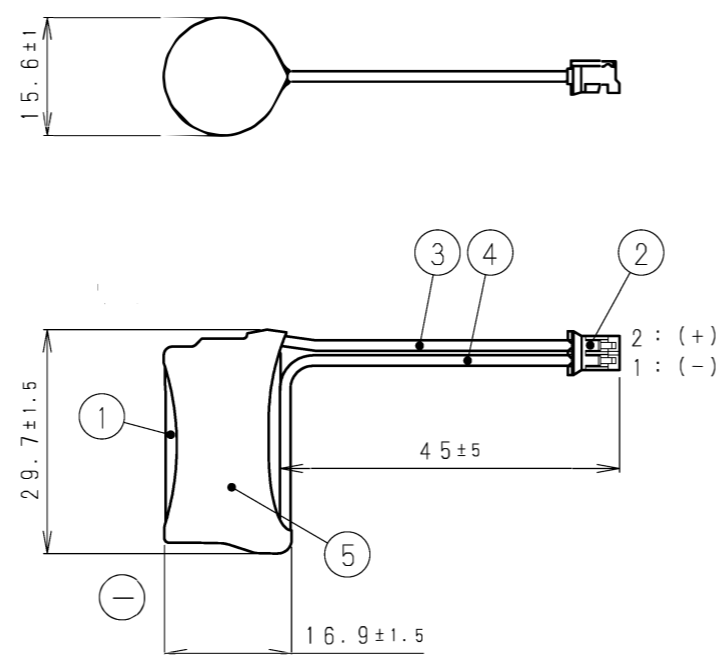

CIRCUIT DIAGRAM  
 [回路図]

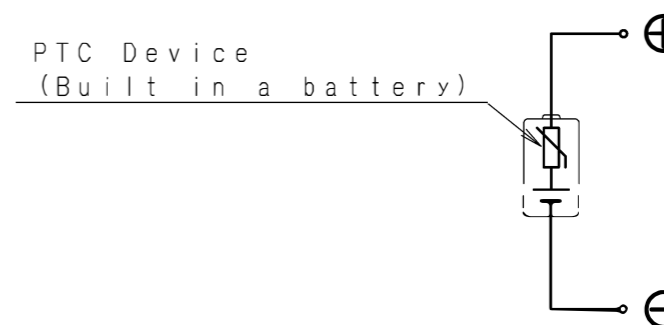

No	CONTENTS [内容]	
①	BATTERY [素電池]	CR2U : PANASONIC BLUE
②	CONNECTOR	JST [日本圧着端子製造]
	HOUSING	SHR-02V-S
	TERMINAL	SSH-003T-P0.2-H : TIN PLATING [Snめっき]
③	(+) LEAD WIRE	UL AWM3302 AWG28 : RED
④	(-) LEAD WIRE	UL AWM3302 AWG28 : BLACK
⑤	INSULATION TAPE	PP TAPE : TRANSPARENT [透明]
⑥	OUTER TUBE [外装チューブ]	HEAT SHRINKABLE TUBE

NOTE [注記]  
 1. NOMINAL VOLTAGE : 3V [公称電圧 : 3V]  
 2. ( ) : REFERENCE DIMENSION AND ANGLE [ ( ) 寸法、角度は参考値]

PRODUCT NO.	CR-2Ux1P (V)	SCALE
		1 : 1
DRAWING NO.	PC-CR-2Ux1P (V)	 UNIT : mm