

未量産品 / Under development
 量産スケジュールについては当社にお問合せ下さい / Please consult Panasonic as for Mass production schedule.
 As of December, 2020.

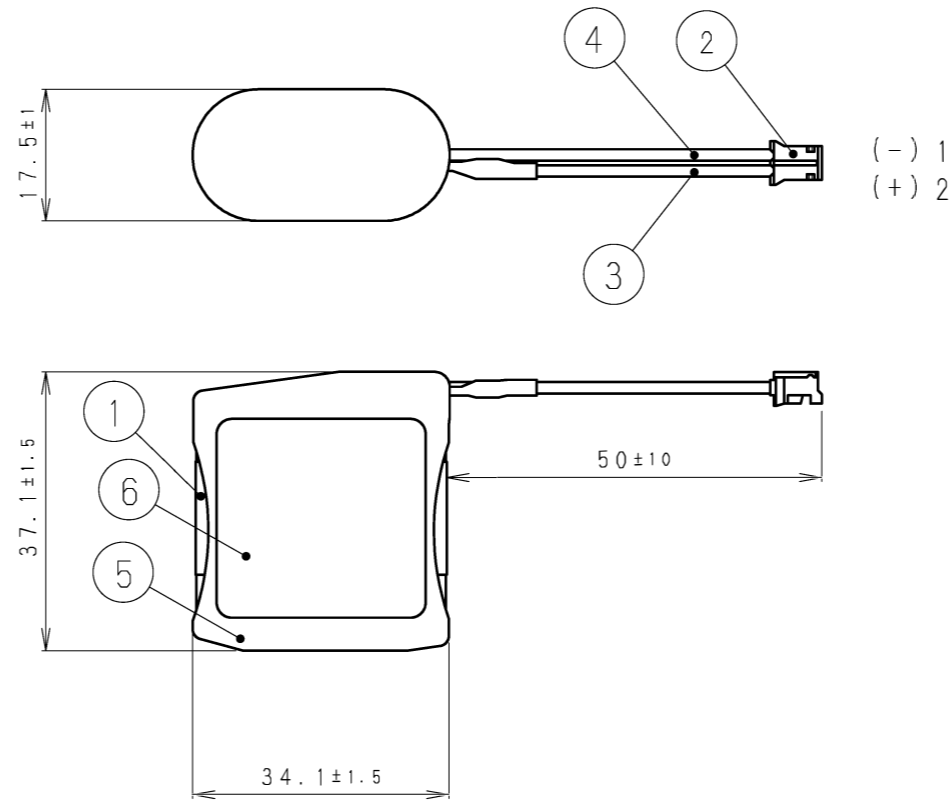

CIRCUIT DIAGRAM
 [回路図]

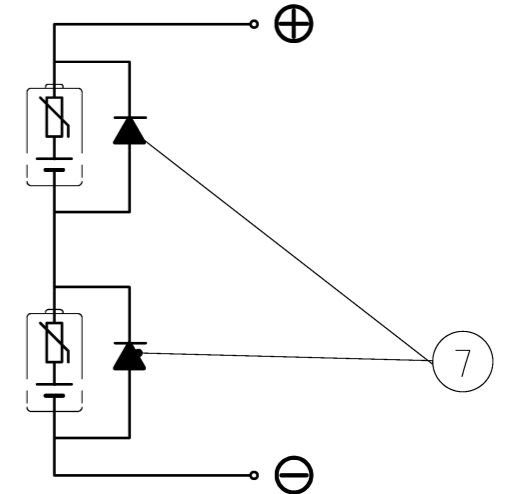

No	CONTENTS [内容]	
①	BATTERY [素電池]	CR-2/3AZ : PANASONIC YELLOW-GREEN 2-BATTERIES SERIES [2本直列]
②	CONNECTOR [コネクタ]	JST [日本圧着端子製造]
	HOUSING [ハウジング]	PHR-2
	TERMINAL [ターミナル]	SPH-002T-P0.5S : TIN PLATING
③	(+) LEAD WIRE [(+) リード線]	UL AWM3385 AWG24 : RED
④	(-) LEAD WIRE [(-) リード線]	UL AWM3385 AWG24 : BLACK
⑤	OUTER TUBE [外装チューブ]	HEAT SHRINKABLE TUBE [熱収縮チューブ]
⑥	LABEL [ラベル]	PET
⑦	PROTECTION DEVICE [保護素子]	DIODE [ダイオード]

NOTE [注記]
 1. NOMINAL VOLTAGE : 6V [公称電圧 : 6V]
 2. () : REFERENCE DIMENSION AND ANGLE [() 寸法、角度は参考値]

PRODUCT NO.	CR-2/3AZx2S (V)	SCALE	1 : 1
DRAWING NO.	PC-CR-2/3AZx2S (V)		UNIT : mm