

Communication Specifications

Model Name : Laser Type PM Sensor
Model NO. : SN-GCJA5
Issue Number : JA5-SSP-COMM-E1.4
Company : Panasonic Photo & Lighting Co., Ltd.
1-1 Saiwai-cho, Takatsuki-city, Osaka, Japan

Customer Approval

Panasonic Photo & Lighting Co., Ltd.		
Approved	Checked	Prepared
Date :	Date :	Date :

【Revision records】

Term	Date	Contents	Approved	Checked
0.0	2018.7.2	Draft issued		Miyashita
0.1	2018.12.25	Corrected UART part on page 7. Added page 8.		Miyashita
0.2	2019.1.18	Add description on “Sensor status”		Sumisaki
1.0	2019.1.18	Officially Issued	Maeda	Sumisaki
1.1	2020.8.27	Correct the comment on page 4.		Sumisaki
1.2	2019.11.27	Revision UART format		Sumisaki
1.3	2020.10.6	Add Timing definition		Sumisaki
1.4	2020.11.12	Add check point		Sumisaki

Communication Specifications (I2C)

● Communication data format

- I2C communication of this sensor complies with 400kbps (FastMode).
- The sensor communicates operate as a slave of the I2C communication.
- SCL terminal of I2C communication is responsible for communication operation from the master side.
- Data structure of I2C communication, the slave address is 7bit, and the memory address is 8bit.
- SCL terminal and the SDA terminal of I2C communication has been pulled up with a 10kΩ of resistance by the sensor internal voltage 3.3V.
- Data sequence of when the output data in I2C communication there is more than one byte, is arranged from low byte to upper byte, in mind "Little-Endian"
Data in each byte is output in the sequence of MSB → LSB.

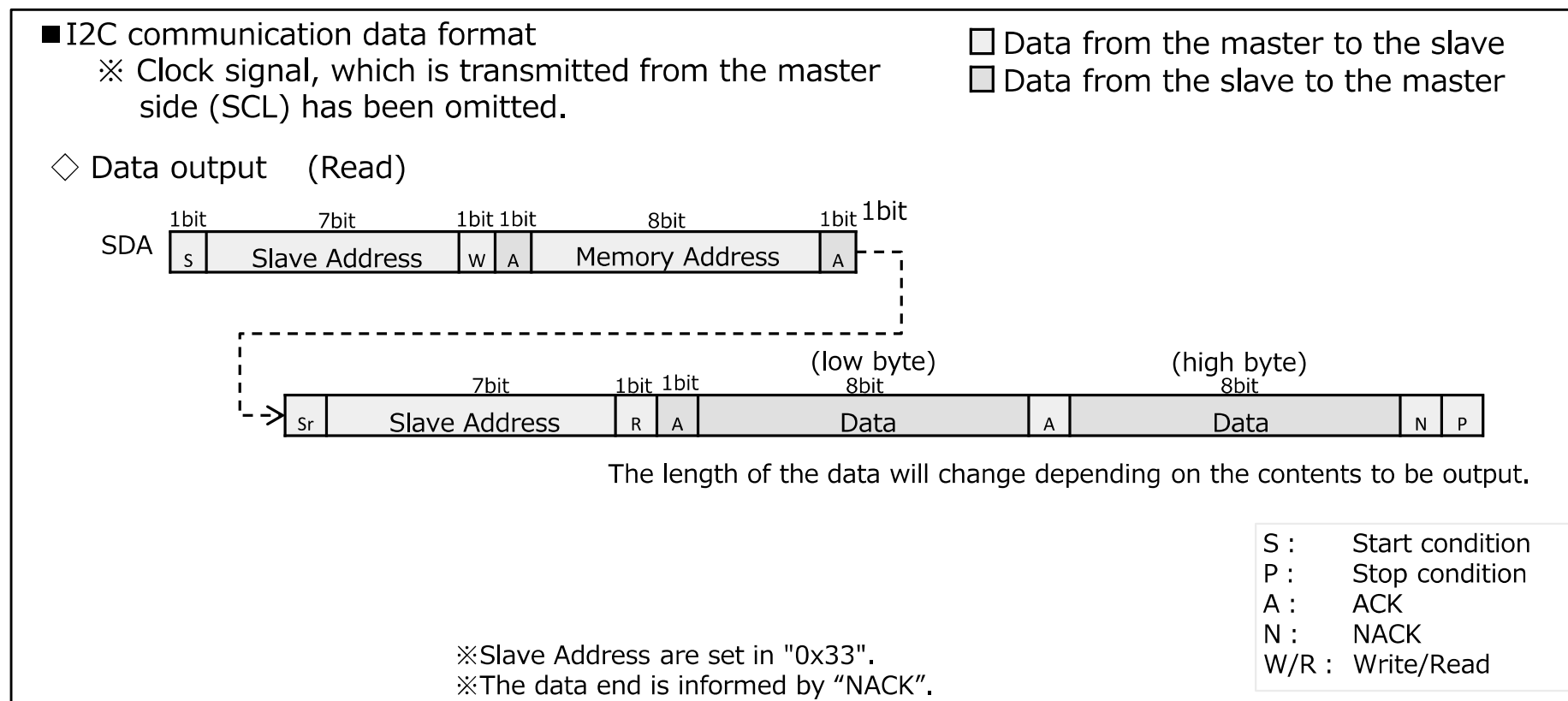

Timing Definition

● Timing Definition

● I2C Fast-mode

Symbol	Parameter	Min	Typ	Max	
fSCL	SCL clock frequency	100		400	kHz
tLOW	SCL clock low time	1.3			us
tHIGH	SCL clock high time	0.6			us
tSU,DAT	SDA set-up time	100			ns
tHD,DAT	SDA hold time	8		900	ns
tSU,STA	Repeated START condition set-up time	0.6			us
tHD,STA	(Repeated) START condition hold time	0.6			us
tSU,STO	STOP condition set-up time	0.6			us
tBUF	Bus free time between a STOP and START condition	1.3			us

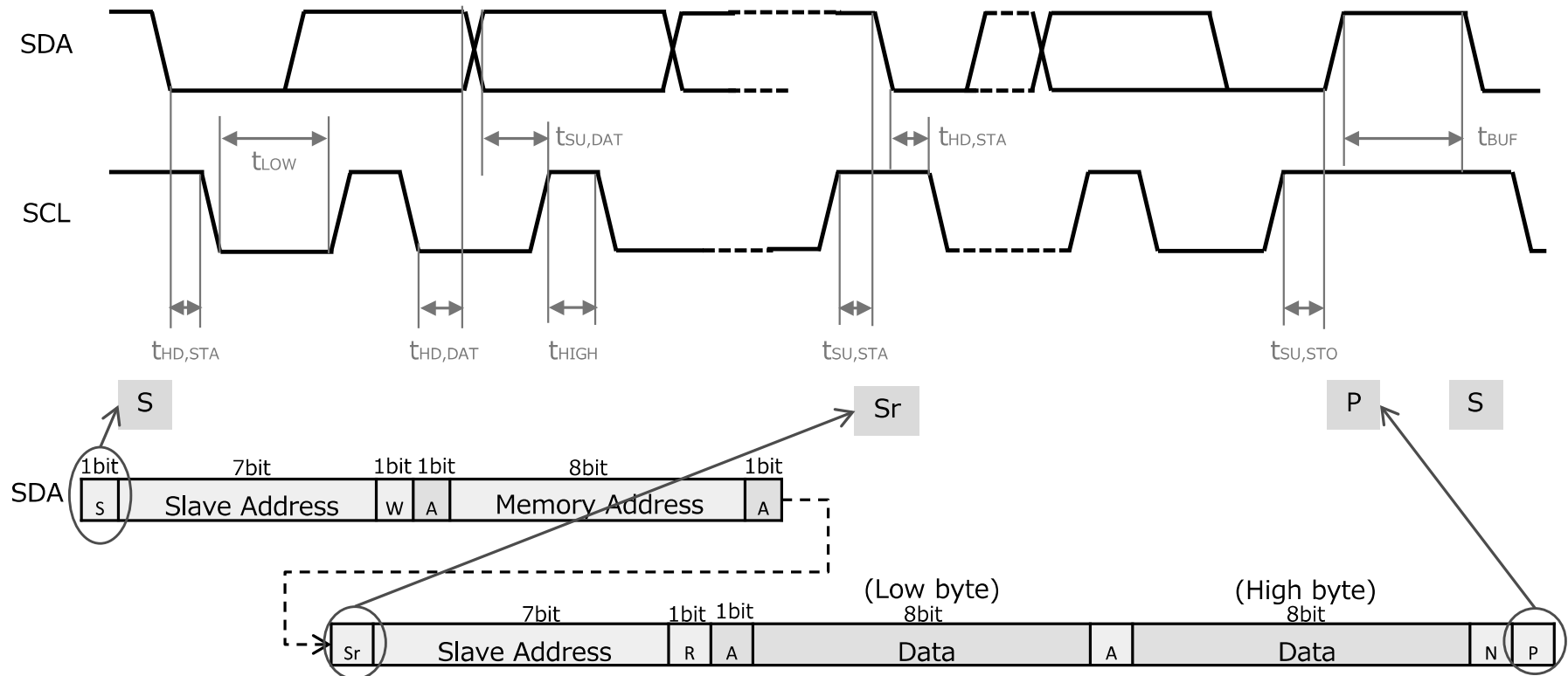

Check point of I2C communication

■ I2C communication data format

※ Clock signal, which is transmitted from the master side (SCL) has been omitted.

- Data from the master to the slave
- ▣ Data from the slave to the master

◇ Data output (Read)

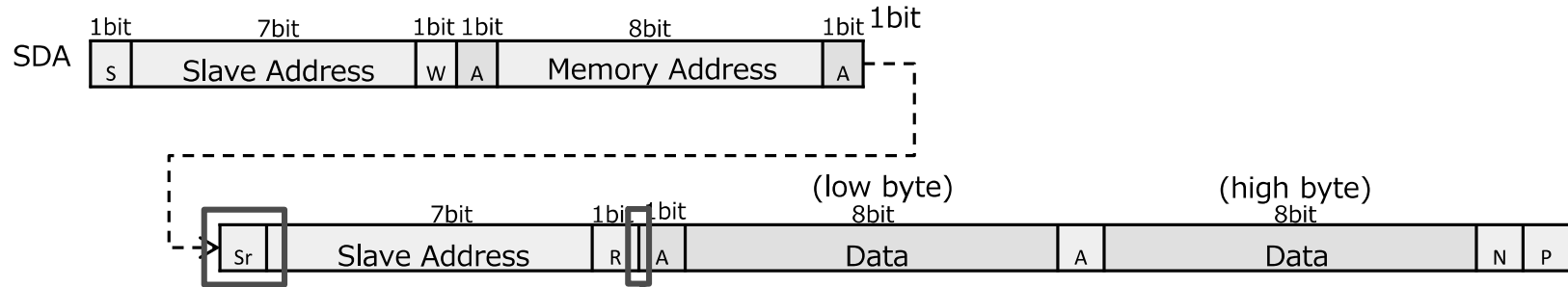

The length of the data will change depending on the contents to be output.

S : Start condition
 P : Stop condition
 A : ACK
 N : NACK
 W/R : Write/Read

※ Slave Address are set in "0x33".
 ※ The data end is informed by "NACK".

Sr : Repeat start condition
Be careful it should NOT be Stop condition

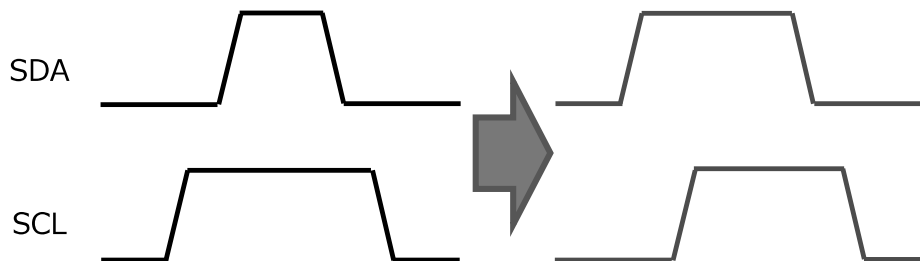

Put the wait more than 500μs before reading the data

Communication Acquired Data (I2C)

Mass-density value conversion data

- On the mass-density value in terms of output register, the mass-density conversion data is stored.
- The mass-density value conversion output register is updated every 1 seconds, can be read out the same data until the next update.

○ Register for PM1.0

address	register	R/W	bit7	bit6	bit5	bit4	bit3	bit2	bit1	bit0	Initial value
0x00	PM1.0_LL	R	M1[7]	M1[6]	M1[5]	M1[4]	M1[3]	M1[2]	M1[1]	M1[0]	0x00
0x01	PM1.0_LH	R	M1[15]	M1[14]	M1[13]	M1[12]	M1[11]	M1[10]	M1[9]	M1[8]	0x00
0x02	PM1.0_HL	R	M1[23]	M1[22]	M1[21]	M1[20]	M1[19]	M1[18]	M1[17]	M1[16]	0x00
0x03	PM1.0_HH	R	M1[31]	M1[30]	M1[29]	M1[28]	M1[27]	M1[26]	M1[25]	M1[24]	0x00

○ Register for PM 2.5

address	register	R/W	bit7	bit6	bit5	bit4	bit3	bit2	bit1	bit0	Initial value
0x04	PM2.5_LL	R	M2[7]	M2[6]	M2[5]	M2[4]	M2[3]	M2[2]	M2[1]	M2[0]	0x00
0x05	PM2.5_LH	R	M2[15]	M2[14]	M2[13]	M2[12]	M2[11]	M2[10]	M2[9]	M2[8]	0x00
0x06	PM2.5_HL	R	M2[23]	M2[22]	M2[21]	M2[20]	M2[19]	M2[18]	M2[17]	M2[16]	0x00
0x07	PM2.5_HH	R	M2[31]	M2[30]	M2[29]	M2[28]	M2[27]	M2[26]	M2[25]	M2[24]	0x00

○ Register for PM10

address	register	R/W	bit7	bit6	bit5	bit4	bit3	bit2	bit1	bit0	Initial value
0x08	PM10_LL	R	M10[7]	M10[6]	M10[5]	M10[4]	M10[3]	M10[2]	M10[1]	M10[0]	0x00
0x09	PM10_LH	R	M10[15]	M10[14]	M10[13]	M10[12]	M10[11]	M10[10]	M10[9]	M10[8]	0x00
0x0A	PM10_HL	R	M10[23]	M10[22]	M10[21]	M10[20]	M10[19]	M10[18]	M10[17]	M10[16]	0x00
0x0B	PM10_HH	R	M10[31]	M10[30]	M10[29]	M10[28]	M10[27]	M10[26]	M10[25]	M10[24]	0x00

- The mass-density value conversion data is the 4-byte data in 32bit.
The sensor output a 1000 times the value. With reading as a 16-bit variable signed and by 1/1000, the mass-density value data is output.
Output example) 15.370 ⇒ 15370 ⇒ 0011 1100 0000 1010 ⇒ 0x3C0A

Communication Acquired Data (I2C)

Particle count data

- The particle count data during TBD sec is stored.
- The particle count data is updated every 1 seconds, can be read out the same data until the next update.

○ Register 1 for particle count (0.3-0.5 μ m)

address	register	R/W	bit7	bit6	bit5	bit4	bit3	bit2	bit1	bit0	Initial value
0x0C	0.5_L	R	[7]	[6]	[5]	[4]	[3]	[2]	[1]	[0]	0x00
0x0D	0.5_H	R	[15]	[14]	[13]	[12]	[11]	[10]	[9]	[8]	0x00

○ Register 2 for particle count (0.5-1.0 μ m)

address	register	R/W	bit7	bit6	bit5	bit4	bit3	bit2	bit1	bit0	Initial value
0x0E	1.0_L	R	[7]	[6]	[5]	[4]	[3]	[2]	[1]	[0]	0x00
0x0F	1.0_H	R	[15]	[14]	[13]	[12]	[11]	[10]	[9]	[8]	0x00

○ Register 3 for particle count (1.0-2.5 μ m)

address	register	R/W	bit7	bit6	bit5	bit4	bit3	bit2	bit1	bit0	Initial value
0x10	2.5_L	R	[7]	[6]	[5]	[4]	[3]	[2]	[1]	[0]	0x00
0x11	2.5_H	R	[15]	[14]	[13]	[12]	[11]	[10]	[9]	[8]	0x00

○ Register 4 for particle count (2.5-5.0 μ m)

address	register	R/W	bit7	bit6	bit5	bit4	bit3	bit2	bit1	bit0	Initial value
0x14	5.0_L	R	[7]	[6]	[5]	[4]	[3]	[2]	[1]	[0]	0x00
0x15	5.0_H	R	[15]	[14]	[13]	[12]	[11]	[10]	[9]	[8]	0x00

○ Register 5 for particle count (5.0-7.5 μ m)

address	register	R/W	bit7	bit6	bit5	bit4	bit3	bit2	bit1	bit0	Initial value
0x16	7.5_L	R	[7]	[6]	[5]	[4]	[3]	[2]	[1]	[0]	0x00
0x17	7.5_H	R	[15]	[14]	[13]	[12]	[11]	[10]	[9]	[8]	0x00

○ Register 6 for particle count (7.5-10.0 μ m)

address	register	R/W	bit7	bit6	bit5	bit4	bit3	bit2	bit1	bit0	Initial value
0x18	10.0_L	R	[7]	[6]	[5]	[4]	[3]	[2]	[1]	[0]	0x00
0x19	10.0_H	R	[15]	[14]	[13]	[12]	[11]	[10]	[9]	[8]	0x00

Communication Acquired Data (I2C)

Sensor status information

- The sensor status information is stored.
- The status information is updated every 1 seconds, can be read out the same data until the next update.

○ Register for sensor status information

address	register	R/W	bit7	bit6	bit5	bit4	bit3	bit2	bit1	bit0
0x26	STATE	R	Sensor status[7] [6]		PD status[5][4]		LD operational status[3][2]		Fan operational status[1][0]	

• Sensor status [7][6]

	PD	LD	FAN
0	0	0	0
1	Any 1, nor 2 & 3		
2	Any 2		
3	Any 3, nor 2		

• PD status [5][4]

- 0 : Normal status
- 1 : Normal status (within -80% against initial value), with S/W correction
- 2 : Abnormal (below -90% against initial value), loss of function
- 3 : Abnormal (below -80% against initial value), with S/W correction

• LD operational status [3][2]

- 0 : Normal status
- 1 : Normal status (within -70% against initial LOP), with S/W correction
- 2 : Abnormal (below -90% against initial LOP) or no LOP, loss of function
- 3 : Abnormal (below -70% against initial LOP), with S/W correction

• Fan operational status [1][0]

- 0 : Normal status
- 1 : Normal status (1,000rpm or more), with S/W correction
- 2 : In initial calibration
- 3 : Abnormal (below 1,000rpm), out of control

Communication Specifications (UART TTL)

● Communication data format

- UART communication complies with 9,600bps.
- The transmitted data packet contains "start bit"(1bit), "data"(8bit), "evenness parity"(1bit) & "stop bit"(1bit), and the data are transmitted by LSB first.
- The data frame contains "header"(1 byte), "data"(several byte), "FCC"(1 byte) & "trailer"(1 byte).
- The header transfers 0x02(start of text).
- Then the data "PM1.0", "PM2.5", "PM10" with each 16bit, 2byte will be output sequentially.
Each data will be updated every 1 sec.
- Output 1 byte XOR on FCC
- The trailer transfers 0x03(end of text).

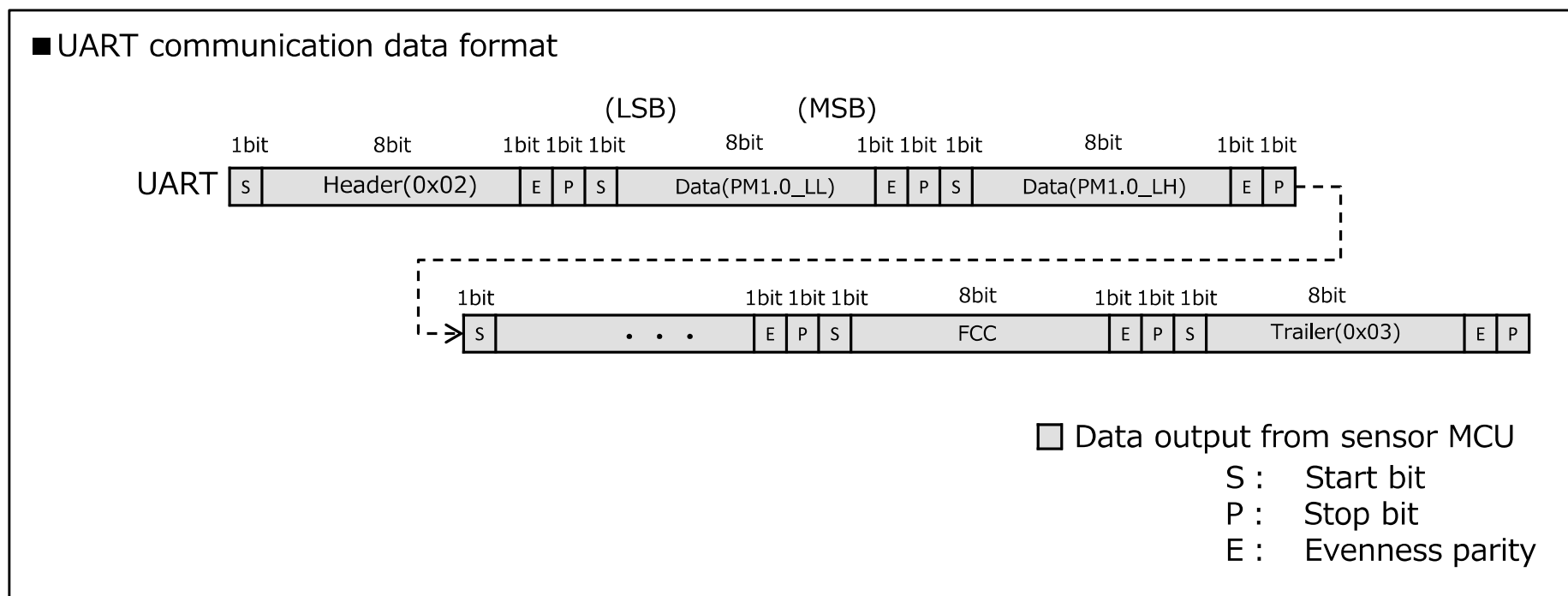

Communication Specifications (UART output data)

Data	Register name	Value	Note
1	STX	0x02	Fixed value
2	PM1.0_LL	-	Register for PM1.0
3	PM1.0_LH	-	
4	PM1.0_HL	-	
5	PM1.0_HH	-	
6	PM2.5_LL	-	Register for PM2.5
7	PM2.5_LH	-	
8	PM2.5_HL	-	
9	PM2.5_HH	-	
10	PM10_LL	-	Register for PM10
11	PM10_LH	-	
12	PM10_HL	-	
13	PM10_HH	-	
14	0.5_L	-	Register 1 for particle count (0.3-0.5 μ m)
15	0.5_H	-	
16	1.0_L	-	Register 2 for particle count (0.5-1.0 μ m)
17	1.0_H	-	
18	2.5_L	-	Register 3 for particle count (1.0-2.5 μ m)
19	2.5_H	-	
20		0x00	Fixed value
21		0x00	Fixed value
22	5.0_L	-	Register 4 for particle count (2.5-5.0 μ m)
23	5.0_H	-	
24	7.5_L	-	Register 5 for particle count (5.0-7.5 μ m)
25	7.5_H	-	
26	10.0_L	-	Register 6 for particle count (7.5-10.0 μ m)
27	10.0_H	-	
28		0x00	Fixed value
29		0x00	Fixed value
30	STATUS	-	Register for sensor status
31	FCC	-	XOR between data 2~30
32	EXT	0x03	Fixed value