

Recommended panel mouting hole dimensions

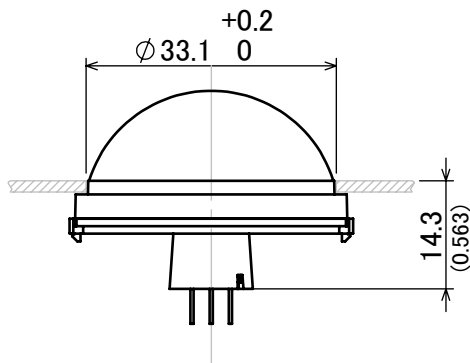

Recommended PC board pattern

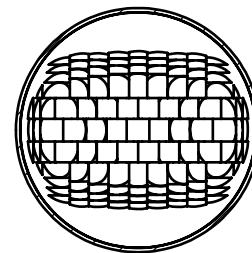
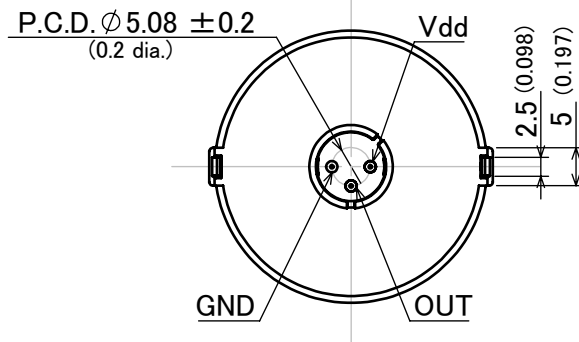
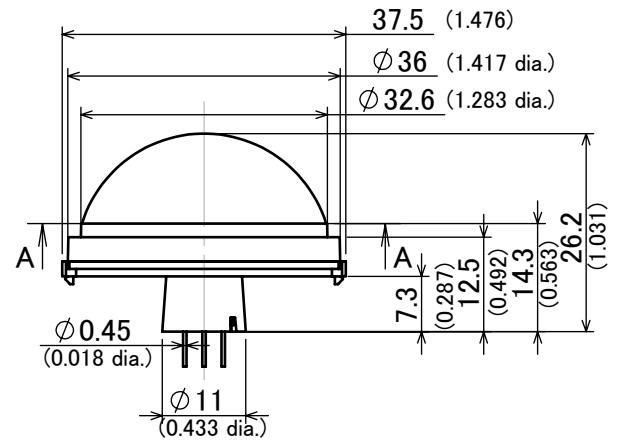
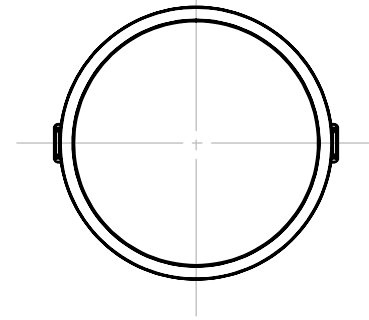
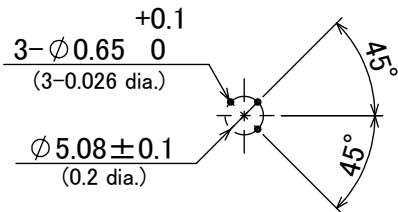

SECTION A-A

Note1 : In order to ensure proper detection, install it with the lens exposed at least 11.9mm (0.469inch).

Note2 : As for panel mouting hole, tapering or making a large size hole should be done.

General tolerance ± 0.5 mm
(± 0.020 inch)

Parts No. EKM***1111**

Date May.21.2023

Name PIR MOTION SENSOR 'PaPIRs' EKM series
(Ultra wide & Long distance detection type)

Scale 1:1 Unit mm

Tolerance

Panasonic Corporation
Electric Works Company