

MEMS Gyro Sensors for Rollover Detection

SMD type

EWTS64G



This series is not recommended for new design.

Click [here](#) for replacement.

This sensor is a gyro sensor for rollover detection which adopts the SMD type. A ceramic package contains a bare chip IC and a MEMS silicon tuning fork whose surface is formed directly by PZT elements.

Moreover, self-diagnostic functions are embedded to achieve high reliability.

Features

- Compact, Low height 5 mm
- SMD type
- High durability against the crash impact or vibration
- 5 V operating voltage (Ratio-metric output)
- Built-in self diagnosis
- RoHS compliant

Recommended Applications

- Automotive rollover detection
- Various types of motion controls for industrial equipment

Ratings

● Electrical Characteristics

Operating Temperature Range	-40 °C to +95 °C
Storage Temperature	-40 °C to +105 °C
Operating Voltage Range	5±0.25 V
Zero Point Voltage (-40 to +95 °C)	2.5±0.15 V
Sensitivity (-40 to +95 °C)	6±0.3 mV/ (° ·s ⁻¹)
Dynamic Range	±300 °/s
Frequency Response (-3 dB)	31 Hz to 61 Hz
Cross Axis Sensitivity	±5 %
Output Noise	< 20 m Vp-p

● Environmental Characteristics

Low Temperature Operation	-40 °C for 1000 h
High Temperature Storage	+105 °C for 1000 h
High Temperature Operation	+95 °C for 1000 h
Thermal Shock	-40 °C to +95 °C for 1000 cycles
Mechanical Shock	19600 m/s ² , 0.5 ms

Dimensions in mm (not to scale)

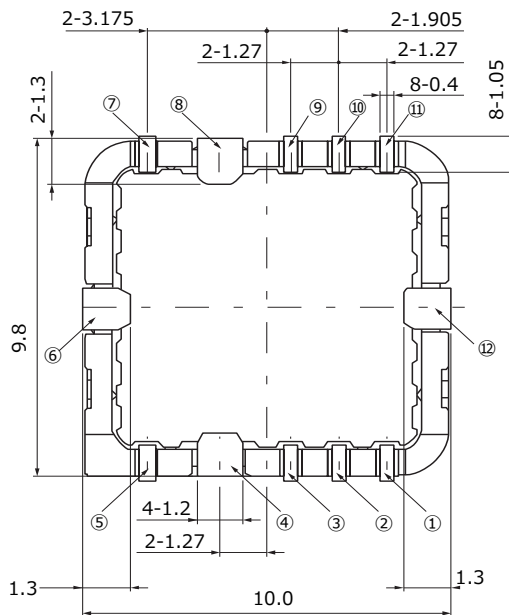
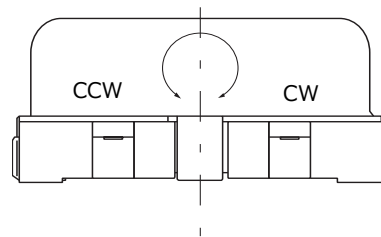
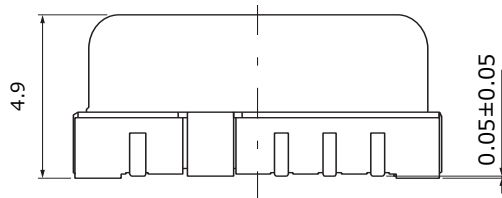
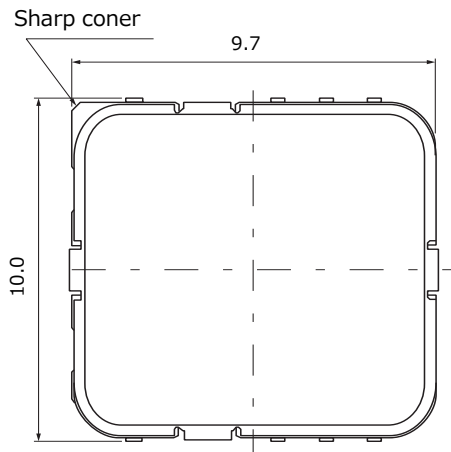

Terminal

①	VDD
②	DIAG
③	NC
④	GND
⑤	CHECK
⑥	GND
⑦	GND
⑧	GND
⑨	NC
⑩	NC
⑪	SIG
⑫	GND

Guidelines and precautions regarding the technical information and use of our products described in this online catalog.

- If you want to use our products described in this online catalog for applications requiring special qualities or reliability, or for applications where the failure or malfunction of the products may directly jeopardize human life or potentially cause personal injury (e.g. aircraft and aerospace equipment, traffic and transportation equipment, combustion equipment, medical equipment, accident prevention, anti-crime equipment, and/or safety equipment), it is necessary to verify whether the specifications of our products fit to such applications. Please ensure that you will ask and check with our inquiry desk as to whether the specifications of our products fit to such applications use before you use our products.
- The quality and performance of our products as described in this online catalog only apply to our products when used in isolation. Therefore, please ensure you evaluate and verify our products under the specific circumstances in which our products are assembled in your own products and in which our products will actually be used.
- If you use our products in equipment that requires a high degree of reliability, regardless of the application, it is recommended that you set up protection circuits and redundancy circuits in order to ensure safety of your equipment.
- The products and product specifications described in this online catalog are subject to change for improvement without prior notice. Therefore, please be sure to request and confirm the latest product specifications which explain the specifications of our products in detail, before you finalize the design of your applications, purchase, or use our products.
- The technical information in this online catalog provides examples of our products' typical operations and application circuits. We do not guarantee the non-infringement of third party's intellectual property rights and we do not grant any license, right, or interest in our intellectual property.
- If any of our products, product specifications and/or technical information in this online catalog is to be exported or provided to non-residents, the laws and regulations of the exporting country, especially with regard to security and export control, shall be observed.

<Regarding the Certificate of Compliance with the EU RoHS Directive/REACH Regulations>

- The switchover date for compliance with the RoHS Directive/REACH Regulations varies depending on the part number or series of our products.
- When you use the inventory of our products for which it is unclear whether those products are compliant with the RoHS Directive/REACH Regulation, please select "Sales Inquiry" in the website inquiry form and contact us.

We do not take any responsibility for the use of our products outside the scope of the specifications, descriptions, guidelines and precautions described in this online catalog.

⚠ Safety Precautions (Gyro Sensors for Rollover detection/EWTS64G□)

1. Soldering

- 1) Thickness of Solder Paste (Recommendation) : 0.15 mm to 0.20 mm
- 2) Flux : Use non-corrosive rosin, and alcohol based solvent with little chemical reaction.
- 3) Pre-heat : Control the temperature on PWB to be under 180 °C and no longer than 120 s.
- 4) Reflow Soldering condition : The Maximum temperature on PWB is 260 °C.
- 5) Atmospheric Temperature : The atmospheric temperature should be under 300 °C.
- 6) Cooling : To avoid deterioration of the sensor due to heat, immediately cool the sensor with blown air.
- 7) Number of times it can be Reflow Soldered : Once.
- 8) Hand soldering (recommendation) : a) Use a 20 W or less soldering iron at less than 350 °C
b) Soldering time: within 3 s

2. Washing

Do not wash.

3. Handling

- 1) Handle with care. Do not drop or apply any strong impact to the sensor this may degrade some performances.
- 2) Do not store under the following conditions, they may degrade some performances and solderability.
 - a) Relative humidity of more than 85 %
 - b) Atmospheres of corrosive gas(Cl₂, H₂S, NH₃, NO_x, SO₂ etc.)
 - c) Long term storage of over 3 months after delivery

Do not store the package under severe load and stress.

4. Pattern layout of the circuit board

See the following recommended pattern design. (mm)

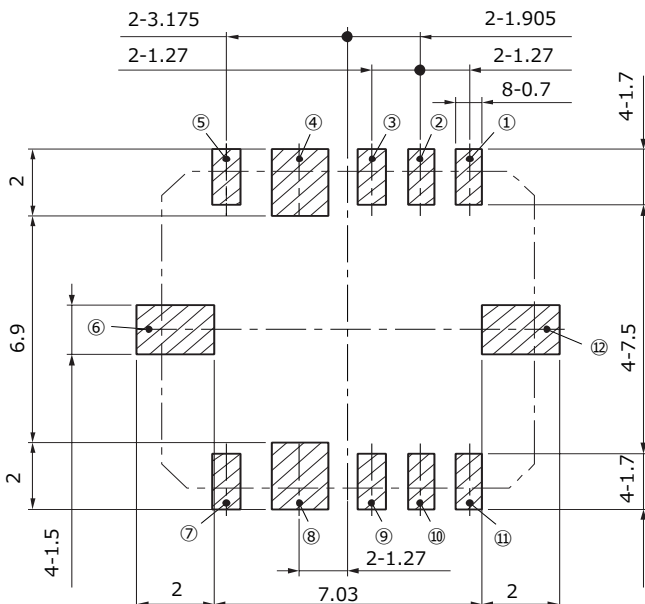

①	VDD
②	DIAG
③	NC
④	GND
⑤	CHECK
⑥	GND
⑦	GND
⑧	GND
⑨	NC
⑩	NC
⑪	SIG
⑫	GND

5. Layout

The sensor has a slight zero point temperature drift due to surrounding conditions. Locate the sensor with care of the following items.

- 1) Do not locate the sensor close to heat radiating objects such as power transistors.
- 2) Do not locate the sensor where it will be effected by heat convection.

6. The application method of a coating agent.

Please apply by the spray system about a coating agent. (Recommendation)

Dip coating of a coating agent is disapproval.

7. Vibration from outside

If the PWB with the sensor is resonant to frequencies caused by external vibrations, take the following items into consideration.

- 1) Rigid glass-epoxy circuit board is recommended. Locate the sensor close to the mounting screws of the PWB. (Since tuning fork part has a resonating point (detuning frequency) between 500 to 900Hz, vibration evaluation in actual use is necessary.)
 - 2) Locate other parts so that they will not touch the sensor directly due to external vibration.
 - 3) Do not allow the mounting screws in the circuit board to become loose.
- * Perform a vibration test and carefully check the condition of the sensor attached to the unit.

8. Recommended circuit

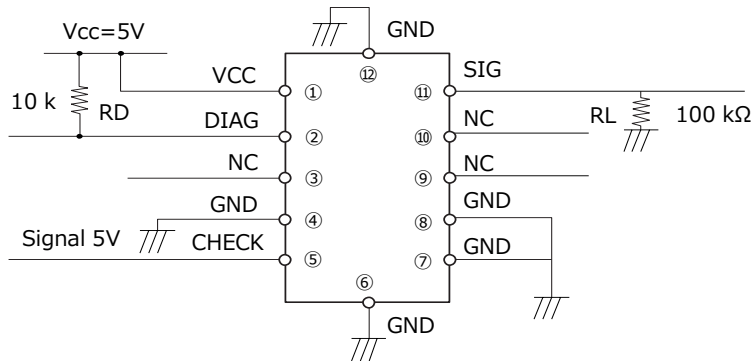

- 1) Be sure to use 100 k load resistors.
- 2) The sensor does not have a power-supply backup capacitor. Insert a backup capacitor in the power supply line close to the sensor when power supply is far or the power is supplied through connectors.
In case of instant power break, vibration of the tuning fork stops and takes 0.5 second to reboot.
- 3) Reverse voltage or over-voltage of more than 6.3 V may destroy the sensor.
- 4) When the sensor signal goes to an A/D converter, use the same 5 V power supply for both the sensor and the A/D converter.
- 5) EMC characteristics depend on whether the shield-case is power grounded or case grounded. Choose which one after evaluating the assembled set.

9. Limited Warranty

Great attention has been paid to the quality of this sensor. As a failure mode, however, zero point output, sensitivity error, instability, or the like may occur. For a single failure of the sensor, study the influence of the whole circuit in advance.

- 1) Install the following systems for a failsafe design to ensure safety if these products are to be used in equipment where a defect in these products may cause the loss of human life or other significant damage, such as damage to vehicles (automobile, train, vessel), trafficlights, medical equipment, aerospace equipment, electric heating appliances, combustion/gas equipment, rotating equipment, disaster/crime prevention equipment, nuclear apparatus, and machine tools.
 1. Systems equipped with a protection circuit and a protection device
 2. Systems equipped with a redundant circuit or other system to prevent an unsafe status in the event of a single fault
- 2) If questions about the safety of this product arise, please do not hesitate to contact our company and be sure to perform the technical assessment.