

CHARGING METHODS

Methods of Charging the Valve Regulated (Sealed) Lead-Acid Battery

For charging the Valve Regulated (Sealed) lead-acid battery, a well-matched charger should be used because the capacity or life of the battery is influenced by ambient temperature, charge voltage and

other parameters.

Charging methods are dependent on battery applications, and the applications are roughly classified into main power application and stand-by/back-up power.

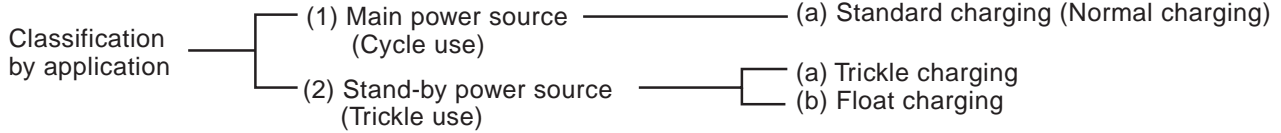

(1) Main Power cycle use

Cycle use is to use the battery by repeated charging and discharging in turn.

(a) Standard charging (Normal charging)

For common applications of the battery, the constant voltage charge method is advantageous as it allows the battery to exert full performance.

- **Constant voltage charging method**

This method is to charge the battery by applying a constant voltage between the terminals. When the battery is charged by applying a voltage of 2.45 V per cell (unit battery) at a room temperature of 20°C to 25°C, charging is complete when the charge current continues to be stable for three hours. Valve Regulated (Sealed) lead-acid batteries can be overcharged without constant voltage control. When the battery is overcharged, the water in the electrolyte is decomposed by electrolysis to generate more oxygen gas than what can be absorbed by the negative electrode. The electrolyte is changed to oxygen gas and hydrogen gas, and lost from the battery system. As the quantity of electrolyte is reduced, the chemical reactions of charge and discharge become inefficient and hence the battery performance is severely deteriorated. Therefore, exact voltage control and proper charging time in constant voltage charging are essential for securing the expected life of the battery.

- **Constant-voltage and constant-current charging method**

This method is to charge the battery by controlling the current at 0.4 CA and controlling the voltage at 2.45 V / per cell (unit battery) at a room temperature of 20°C to 25°C. Proper charging time is 6 to 12 hours depending on discharge rate.

Constant-voltage constant-current charge characteristics

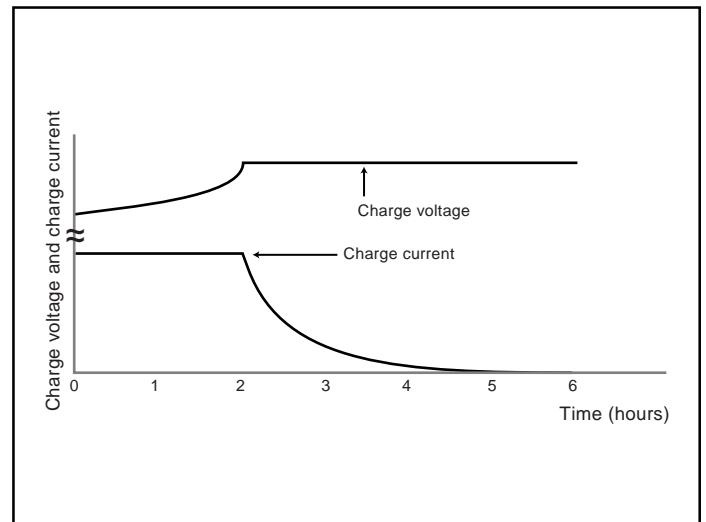

CHARGING METHODS - CONTINUED

- **Two-step constant voltage charge control method**

Two-step constant voltage charge control method uses two constant-voltage devices. At the initial stage, the battery is charged by the first constant-voltage device SW(1) of high setup voltage (set-up for cycle charge voltage). When the charge current, the value of which is detected by the current-detection circuit, has reduced to the preset value, the device is switched over to the second SW(2) of low set-up voltage (setup for trickle charge voltage). This method has the advantage that the battery in trickle use can be charged in a comparatively short time for the next discharge.

Charging characteristics of the two-step constant voltage control charger

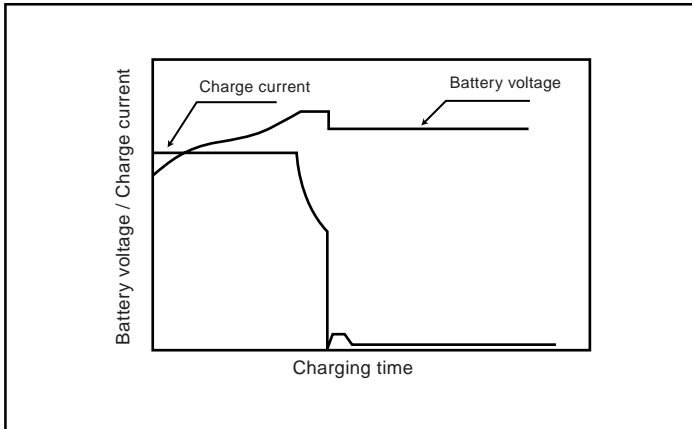

Block diagram of the two-step constant voltage control charger

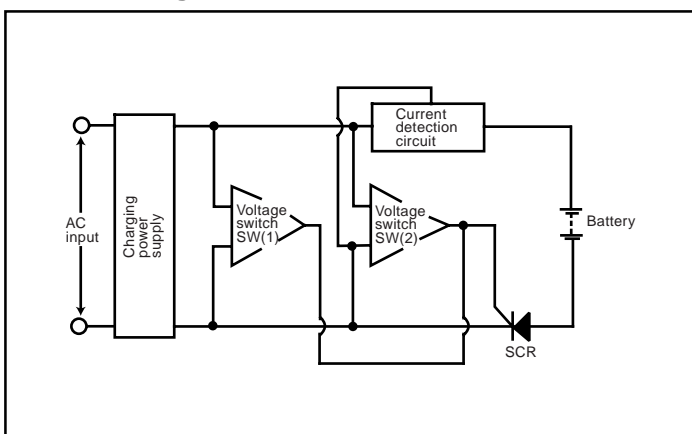

CHARGING METHODS - CONTINUED

(1) Stand-by/Back-up use (Trickle use)

The application load is supplied with power from AC sources in normal state. Stand-by/back-up use is to maintain the battery system at all times so that it can supply power to the load in case the AC input is disrupted (such as a power failure). There are two methods of charging for this use.

(a) Trickle charge (Compensating charge)

• Trickle charge

In this charge system, the battery is disconnected from the load and kept charged with a small current only for compensating self discharge while AC power is alive. In case of power failure, the battery is automatically connected to the load and battery power is supplied. This system is applied mainly as a spare power source for emergency equipment. In this use, if rapid recovery of the battery after discharge is required, it is necessary to consider the recovery charge with a comparatively large current followed by trickle charge, or alternative measures.

While the type and capacity of the battery is determined by the back-up time and the load (current consumption) during power failure, some reserve power should be taken into account considering such factors as ambient temperature, capability of the charger and depth of discharge.

Trickle charge system model

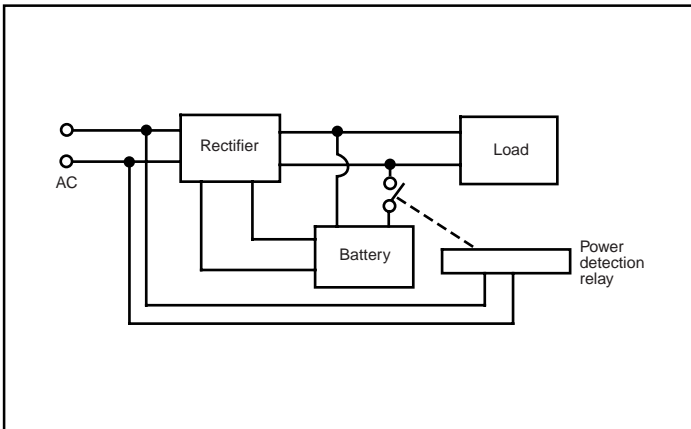

(Precautions on charging)

1. As the battery continues to be charged over a long period, a small difference in charging voltage may result in a significant difference in the battery life. Therefore, charge voltage should be controlled within a narrow range and with little variation for a long period.
2. As charge characteristics of the battery are dependent on temperature, compensation for temperature variation is required when the battery is used over a broad temperature range, and the system should be designed so that the battery and the charger are kept at the same temperature.

• Float charge

Float system is the system in which the battery and the load are connected in parallel to the rectifier, which should supply a constant-voltage current.

Float charge system model

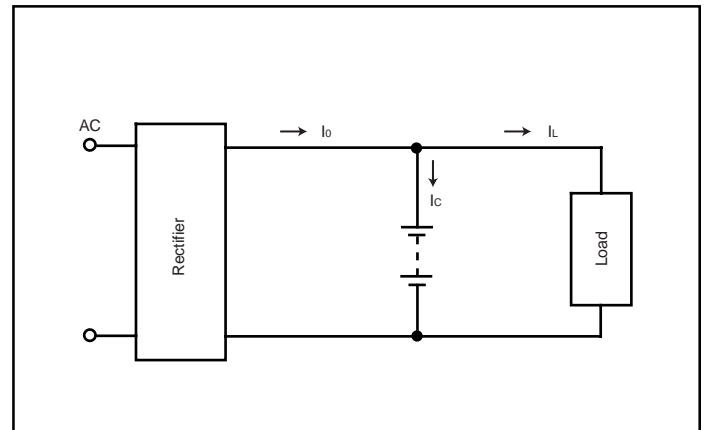

In the above-illustrated model, output current of the rectifier is expressed as:

$I_o = I_c + I_L$ where I_c is charge current and I_L is load current. Consideration should be given to secure adequate charging because, in fact, load current is not constant but irregular in most cases.

In the float system, capacity of the constant-voltage power source should be more than sufficient against the load. Usually, the rectifier capacity is set at the sum of the normal load current plus the current needed in order to charge the battery.

CHARGING METHODS - CONTINUED

Charging Methods and Applications of VRLA Batteries

Application/ Charging Method	Normal charging in 6 or more hours; Constant voltage control	Two-step constant voltage control	Constant current control
Cycle use	Control voltage : 7.25V to 7.45V /6V battery 14.5V to 14.9V /12V battery Initial current : 0.4 CA or smaller	—	—
Trickle use	Control voltage : 6.8V to 6.9V /6V battery 13.6V to 13.8V /12V battery	Initial charging with current of approx. 0.15 CA, followed by switching voltage to trickle charge	—
Float use	Control voltage : 6.8V to 6.9V /6V battery 13.6V to 13.8V /12V battery Float charging compensates for load fluctuations.	—	—
Refresh charge (Auxiliary charge)*	When charging two or more batteries at a time, select only those which have been left under the same condition.	—	Charging with current of approx. 0.1 CA
Application example	General uses, Cellular phones (bag phones), UPS, Lanterns, Electric tools	Medical equipment, Personal radios	—

Note * Refresh (auxiliary) charge amount should be 120% to 130 % of self-discharge amount. For details, please contact us.

(Precautions on charging)

- (a) in constant voltage charging (cycle use): Initial current should be 0.4 CA or smaller (C: rated capacity)
(b) in constant voltage charging (trickle use): Initial current should be 0.15 CA or smaller (C: rated capacity)
- Relation between standard voltage value in constant voltage charging and temperature is given in the Table.

Relation between standard voltage value in constant voltage charging and temperature

		0°C	25°C	40°C
Cycle use	6V	7.7	7.4	7.1
	12V	15.4	14.7	14.2
Trickle use	6V	7.1	6.8	6.7
	12V	14.1	13.7	13.4

CHARGING METHODS - CONTINUED

a) Temperature compensation of charge voltage

Charge voltage should be compensated to the ambient temperature near the battery, as shown by the figure below. Main reasons for the temperature compensation of charge voltage are to prevent the thermal runaway of the battery when it is used in high temperature conditions and to secure sufficient charging of the battery when it is used in low temperature conditions. Prolongation of service life of the battery by the above-described temperature compensation is expected as follows

- At 30°C: prolonged by approx. 5 %
- At 35°C: prolonged by approx. 10 %
- At 40°C: prolonged by approx. 15 %

In low temperature zones below 20°C, no substantial prolongation of the battery life can be expected by the temperature compensation of charge voltage.

Compensated voltage value

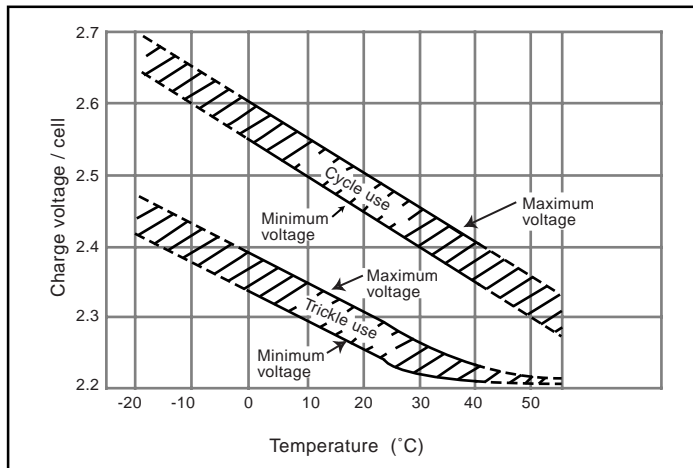

b) Charging time

Time required to complete charging depends on factors such as depth of discharge of the battery, characteristics of the charger and ambient temperature. For cycle charge, charging time can be estimated as follows:

(1) when charge current is 0.25 CA or greater:

$$T_{ch} = C_{dis} / I + (3 \text{ to } 5)$$

(2) when charge current is below 0.25 CA:

$$T_{ch} = C_{dis} / I + (6 \text{ to } 10), \text{ where}$$

T_{ch} : Charging time required (hours)

C_{dis} : Amount of discharge before this charging (Ah)

I : Initial charge current (A)

Time required for trickle charge ranges from 24 to 48 hours.

c) Charging temperature

- (1) Charge the battery at an ambient temperature in the range from 0°C to 40°C.
- (2) Optimum temperature range for charging is 5°C to 35°C.
- (3) Charging at 0°C or below and 40°C or higher is not recommended: at low temperatures, the battery may not be charged adequately; at high temperatures, the battery may become deformed.
- (4) For temperature compensation values, see a).

d) Reverse charging

Never charge the battery in reverse, as it may cause leakage, heating or bursting of the battery.

e) Overcharging

Overcharge is an additional charge after the battery is fully charged. Continued overcharging shortens the battery life. Select a charge method which is specified or approved for each application.

f) Charging before use

Recharge the battery before use to compensate for capacity loss due to self-discharge during storage. (See "Refresh charge" (auxiliary charge) table on page 22.)

CHARGING METHODS - CONTINUED

• Characteristics of constant voltage chargers

Even with the same voltage set-up, charging time varies with output V-I characteristics.

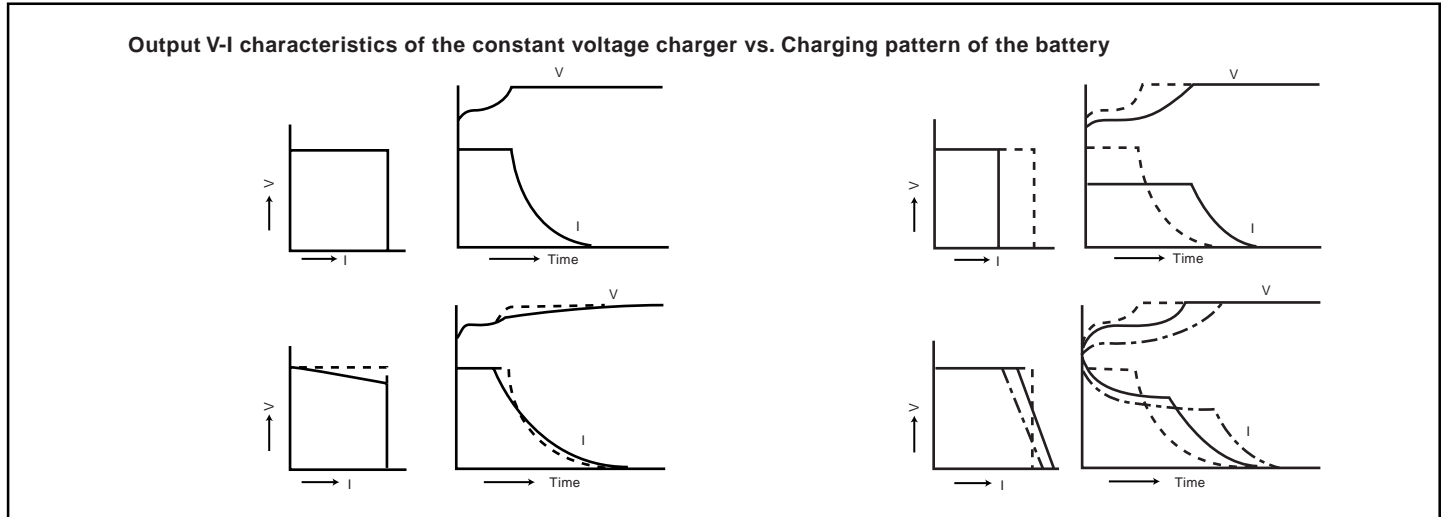

Precautions

- 1) When adopting charging methods and charging conditions other than those described in the specifications or the brochures, thoroughly check charging/discharging characteristics and life characteristics of the battery in advance. Selection of appropriate methods and conditions of charging is essential for safe use of the battery and for fully utilizing its discharge characteristics.
 - 2) In cyclic use of the battery, use a charger equipped with a charging timer or a charger in which charging time or charge amount is controlled by other means; otherwise, it will be difficult to judge the completion of the charge. Use of a charger as described above is recommended to prevent undercharge or overcharge which may cause deterioration of the battery characteristics.
 - 3) Continue charging the battery for the specified time or until the charge completion lamp, if equipped, indicates completion of charging. Interruption of charging may cause a shortening of service life.
 - 4) Do not recharge the fully charged battery repeatedly, as overcharge may accelerate deterioration of the battery.
 - 5) In cyclic use of the battery, do not continue charging for 24 hours or longer, as it may accelerate deterioration of the battery.
 - 6) In cyclic service of the battery, avoid charging two or more batteries connected in parallel simultaneously: imbalance of charge/discharge amount among the batteries may shorten the life of batteries.
 - 7) Please see the following for designing chargers.
 - * Chargers and batteries should be connected by thick and short wire to avoid big dropping voltage of the battery.
(Especially for constant voltage charging method for cycle use)
Big voltage drop will cause the situation that service life of the battery will be shortened.
- Please install diode to avoid flowing reverse current into chargers after charging stops.
 - After a long storage or long use, voltage of the battery may be around 0V because of its internal short circuited. Please make chargers endure such situation.
Never use the battery which is short circuited once.
 - Please make chargers safe if batteries and chargers should be connected improperly.