

**Conductive Polymer Aluminum
Solid Capacitors**
Surface Mount Type
SVP series



Features

- Standard
- RoHS compliance, Halogen free

Specifications

Size code	A5	B6	C6	E7	E12	F8	F12
Category temp. range	-55 °C to +105 °C						
Rated voltage range (V)	4.0 to 16	4.0 to 20	2.5 to 20	4.0 to 20	2.5 to 20	4.0 to 20	2.5 to 20
Nominal cap.range (μF)	3.3 to 33	10 to 68	22 to 220	33 to 330	100 to 680	56 to 680	150 to 1500
Capacitance tolerance	±20 % (120 Hz / +20 °C)						
DC leakage current	Please see the attached characteristics list						
Dissipation factor (tan δ)	Please see the attached characteristics list						
Endurance	+105 °C 2000 h, rated voltage applied						
	Capacitance change	Within ±20 % of the initial value					
	Dissipation factor (tanδ)	≤ 150 % of the initial limit					
	DC leakage current	Within the initial limit					
Damp heat (Steady state)	+60 °C, 90 % to 95 % RH, 1000 h, No-applied voltage						
	Capacitance change	Within ±20 % of the initial value					
	Dissipation factor (tanδ)	≤ 150 % of the initial limit					
	DC leakage current	Within the initial limit (after voltage processing)					

Marking

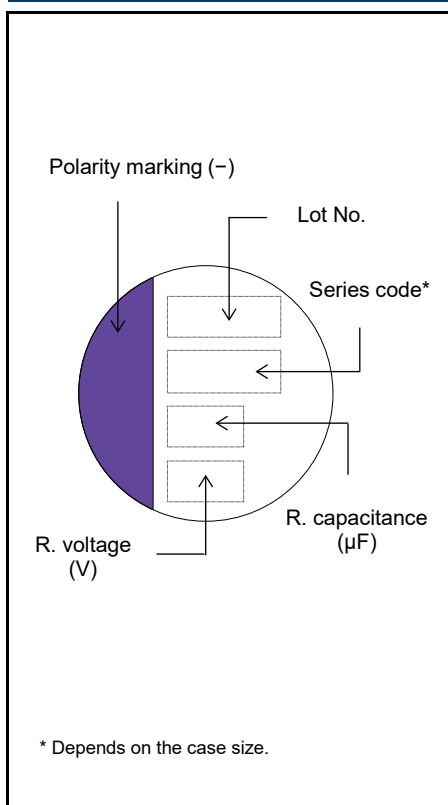

Dimensions (not to scale)

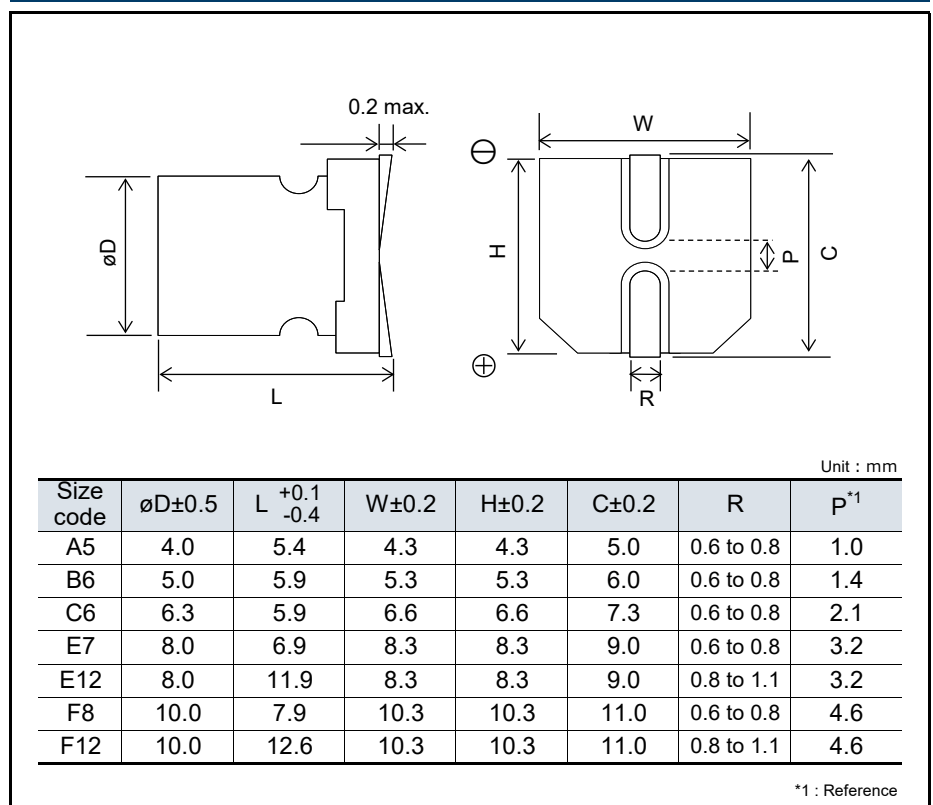

Characteristics list

Rated voltage (V)	Rated capacitance ($\pm 20\%$) (μF)	Case size (mm)		Size code	Specifications				Standard (Reel size : $\phi 380$)	
		ϕD	L		Ripple current ^{*1} (mA rms)	ESR ^{*2} (m Ω max.)	$\tan \delta$ ^{*3}	LC ^{*4} (μA)	Part number	Min. Packaging Qty (pcs)
2.5	220	6.3	5.9	C6	2390	23	0.12	110	2R5SVP220M	1000
	680	8.0	11.9	E12	4520	13	0.15	340	2R5SVP680M	400
	1500	10.0	12.6	F12	5440	12	0.18	750	2R5SVP1500M	400
4.0	33	4.0	5.4	A5	740	200	0.15	66	4SVP33M	2000
	39	5.0	5.9	B6	1100	70	0.12	78	4SVP39M	1500
	68	5.0	5.9		1400	60	0.12	136	4SVP68M	1500
	150	6.3	5.9	C6	1810	40	0.12	120	4SVP150MX	1000
	330	8.0	6.9	E7	2560	35	0.12	264	4SVP330M	1000
	560	8.0	11.9	E12	4520	13	0.15	448	4SVP560M	400
	680	10.0	7.9	F8	3700	25	0.12	544	4SVP680M	500
	1200	10.0	12.6	F12	5440	12	0.18	960	4SVP1200M	400
6.3	22	4.0	5.4	A5	740	200	0.12	69.3	6SVP22M	2000
	47	5.0	5.9	B6	1100	70	0.12	148	6SVP47M	1500
	82	6.3	5.9	C6	1700	45	0.12	103	6SVP82M	1000
	100	6.3	5.9		1810	40	0.12	126	6SVP100M	1000
	120	6.3	5.9		2780	17	0.12	151	6SVP120MV	1000
	220	8.0	6.9	E7	2560	35	0.12	277	6SVP220MX	1000
	330	10.0	7.9	F8	3700	25	0.12	277	6SVP220M	500
		10.0	7.9		3700	25	0.12	416	6SVP330M	500
	470	10.0	7.9	E12	3700	25	0.12	592	6SVP470MX	500
		8.0	11.9		4210	15	0.15	592	6SVP470M	400
	820	10.0	12.6	F12	5440	12	0.15	775	6SVP820M	400
10	4.7	4.0	5.4	A5	670	240	0.08	23.5	10SVP4R7M	2000
	6.8	4.0	5.4		670	240	0.09	34	10SVP6R8M	2000
	10	4.0	5.4		700	220	0.10	50	10SVP10M	2000
	15	4.0	5.4		740	200	0.10	75	10SVP15M	2000
	33	5.0	5.9	B6	1100	70	0.12	165	10SVP33M	1500
	47	6.3	5.9	C6	1620	50	0.12	94	10SVP47M	1000
	56	6.3	5.9		1700	45	0.12	112	10SVP56M	1000
	120	8.0	6.9	E7	2560	35	0.12	240	10SVP120M	1000
	150	8.0	6.9	F8	2560	35	0.12	300	10SVP150MX	1000
		10.0	7.9		3020	30	0.12	300	10SVP150M	500
	270	10.0	7.9	E12	3700	25	0.12	540	10SVP270M	500
	330	10.0	7.9		3700	25	0.12	660	10SVP330MX	500
		8.0	11.9	3950	17	0.15	660	10SVP330M	400	
	560	10.0	12.6	F12	5230	13	0.15	840	10SVP560M	400
	16	3.3	4.0	5.4	A5	660	260	0.07	26.4	16SVP3R3M
15		5.0	5.9	B6	1020	120	0.10	120	16SVP15M	1500
22		5.0	5.9		1060	90	0.10	176	16SVP22M	1500
39		6.3	5.9	C6	1620	50	0.10	125	16SVP39M	1000
56		8.0	6.9	E7	1890	45	0.12	179	16SVP56M	1000
82		8.0	6.9		2120	40	0.12	262	16SVP82M	1000
100		10.0	7.9	F8	2670	35	0.12	320	16SVP100M	500
150		10.0	7.9		3020	30	0.12	480	16SVP150M	500
180		10.0	7.9		3020	30	0.12	576	16SVP180MX	500
		8.0	11.9	E12	3640	20	0.15	576	16SVP180M	400
330		10.0	12.6	F12	4720	16	0.15	792	16SVP330M	400
20	10	5.0	5.9	B6	1020	120	0.10	100	20SVP10M	1500
	22	6.3	5.9	C6	1450	60	0.10	88	20SVP22M	1000
	27	6.3	5.9		1450	60	0.10	108	20SVP27M	1000
	33	8.0	6.9	E7	1890	45	0.12	132	20SVP33M	1000
	47	8.0	6.9		1890	45	0.12	188	20SVP47M	1000
	56	10.0	7.9	F8	2400	40	0.12	224	20SVP56M	500
	68	10.0	7.9		2400	40	0.12	272	20SVP68M	500
	100	8.0	11.9		E12	3320	24	0.15	400	20SVP100M
	150	10.0	12.6	F12	4320	20	0.15	600	20SVP150M	400

*1: Ripple current (100 kHz / +105 °C)

*2: ESR (100 kHz to 300 kHz/+20 °C)

*3: $\tan \delta$ (120 Hz / +20 °C)

*4: After 2 minutes

◆ Please refer to each page in this catalog for "Reflow conditions" and "Taping specifications".

Frequency correction factor for ripple current

Frequency(f)	120 Hz \leq f < 1 kHz	1 kHz \leq f < 10 kHz	10 kHz \leq f < 100 kHz	100 kHz \leq f < 500 kHz
Coefficient	0.05	0.3	0.7	1

Safety and Legal Matters to Be Observed

Product specifications and applications

- Please be advised that this product and product specifications are subject to change without notice for improvement purposes. Therefore, please request and confirm the latest delivery specifications that explain the specifications in detail before the final design, or purchase or use of the product, regardless of the application. In addition, do not use this product in any way that deviates from the contents of the company's delivery specifications.
- Unless otherwise specified in this catalog or the product specifications, this product is intended for use in general electronic equipment (AV products, home appliances, commercial equipment, office equipment, information and communication equipment, etc.).
When this product is used for the following special cases, the specification document suited to each application shall be signed/sealed (with Panasonic Industry and the user) in advance..These include applications requiring special quality and reliability, wherein their failures or malfunctions may directly threaten human life or cause harm to the human body (e.g.: space/aircraft equipment, transportation/traffic equipment, combustion equipment, medical equipment, disaster prevention/crime prevention equipment, safety equipment, etc.).

Safety design and product evaluation

- Please ensure safety through protection circuits, redundant circuits, etc., in the customer's system design so that a defect in our company's product will not endanger human life or cause other serious damage.
- This catalog shows the quality and performance of individual parts. The durability of parts varies depending on the usage environment and conditions. Therefore, please ensure to evaluate and confirm the state of each part after it has been mounted in your product in the actual operating environment before use.
If you have any doubts about the safety of this product, then please notify us immediately, and be sure to conduct a technical review including the above protection circuits and redundant circuits at your company.

Laws / Regulations / Intellectual property

- The transportation of dangerous goods as designated by UN numbers, UN classifications, etc., does not apply to this product. In addition, when exporting products, product specifications, and technical information described in this catalog, please comply with the laws and regulations of the countries to which the products are exported, especially those concerning security export control.
- Each model of this product complies with the RoHS Directive (Restriction of the use of hazardous substances in electrical and electronic equipment) (2011/65/EU and (EU) 2015/863). The date of compliance with the RoHS Directive and REACH Regulation varies depending on the product model.
Further, if you are using product models in stock and are not sure whether or not they comply with the RoHS Directive or REACH Regulation, please contact us by selecting "Sales Inquiry" from the inquiry form.
- During the manufacturing process of this product and any of its components and materials to be used, Panasonic Industry does not intentionally use ozone-depleting substances stipulated in the Montreal Protocol and specific bromine-based flame retardants such as PBBs (Poly-Brominated Biphenyls) / PBDEs (Poly-Brominated Diphenyl Ethers). In addition, the materials used in this product are all listed as existing chemical substances based on the Act on the Regulation of Manufacture and Evaluation of Chemical Substances.
- With regard to the disposal of this product, please confirm the disposal method in each country and region where it is incorporated into your company's product and used.
- The technical information contained in this catalog is intended to show only typical operation and application circuit examples of this product. This catalog does not guarantee that such information does not infringe upon the intellectual property rights of Panasonic Industry or any third party, nor imply that the license of such rights has been granted.
- Design, materials, or process related to technical owned by Panasonic Industry are subject to change without notice.

Panasonic Industry will assume no liability whatsoever if the use of our company's products deviates from the contents of this catalog or does not comply with the precautions. Please be advised of these restrictions.

Matters to Be Observed When Using This Product (Conductive Polymer Aluminum Solid Capacitors / OS-CON)

Use environments and cleaning conditions

- This product (capacitor) is intended for standard general-purpose use in electronic equipment, and is not designed for use in the specific environments described below. Using the product in such specific environments or service conditions, therefore, may affect the performance of the product.

Please check with us about the performance and reliability of the product first before using the product.

- (1) Used in liquid, such as water, oil, chemicals, and organic solvents.
- (2) Used in a place exposed to direct sunlight, an outdoor place with no shielding, or a dusty place.
- (3) Used in a wet place (dew concentration on a resistor, water leakage, etc.), a place exposed to sea breeze, or a place filled with a corrosive gas, such as Cl₂, H₂S, NH₃, SO₂, or NO_x.
- (4) Used in an environment where static electricity and electromagnetic waves are strong.
- (5) The product is located close to a heating component or a flammable material, such as a vinyl cable, is placed near the product.
- (6) The product is used sealed with a resin, etc.
- (7) Solder flux of the soldered product is cleansed with a solvent, water, and a water-soluble cleaner.
(Be careful with water soluble solder flux.)
- (8) Used in an environment where an acidic or alkali atmosphere is present.
- (9) Used in an environment where excessive vibration or impact is applied to the product.
- (10) Used under a low atmospheric pressure condition or depressurized condition.

- Cleaning can be performed with cleaning agents, including higher-grade alcohol-based cleaning solutions such as Pine Alpha ST-100S, Cleanthru 750H, 750L, 710M, 750K, Techno Care FRW14-17, CFC substitutes such as AK-225AES, and IPA. Please confirm the following precautions before cleaning.

- (1) Use an immersion, ultrasonic wave, or other cleaning method, and the cleaning time should not exceed 2 minutes.
- (2) The temperature of the cleaning solution should be less than or equal to 60°C.
- (3) Control contamination of cleaning agents (conductivity, pH, specific gravity, water content, etc.).
- (4) After cleaning, do not store the product in the atmosphere of the cleaning solution or in an airtight container.
- (5) When drying the circuit board or this product, use hot air below the upper limit temperature of their category.
- (6) Please be mindful that rubbing the printed surface of this product after cleaning may erase the markings depending on the cleaning agent used.
- (7) Please contact us separately for details on cleaning agents, cleaning methods, etc., and for cleaning solutions other than those listed above.

- Fixing agents and coating agents

- (1) Select appropriate materials for the outer packaging and sealing materials of this product. Do not use acetone, especially in fixing agents, coating agents, or diluents.
- (2) When using a fixing agent or coating agent, ensure that no flux residue or contamination remains between the circuit board and the sealing area of this product.
- (3) Allow cleaning agents, etc. to dry before using fixing agents or coating agents.
- (4) Please contact us for thermal curing conditions for fixing agents or coating agents.

- When the capacitor is used in a circuit where an impact voltage is applied or a high voltage is applied in a short period (transient phenomenon) or a high pulse voltage is applied, make sure to use the capacitor at a voltage equal to or lower than its rated voltage.

Response to anomalies and handling conditions

- The main failure mode is a short-circuit mode caused mainly by thermal stress, electrical stress, and mechanical stress due to soldering and operating temperature environments. To prevent the occurrence of short circuits, the following measures should be adequately taken to ensure safety.
 - (1) If odorous gases are generated, then turn off the main power of the set equipment and stop using it.
In this case, keep your face and hands away from the equipment.
 - (2) Depending on conditions, it may take several seconds to several minutes before odorous gases are generated.
When using a protection circuit, design it so that it operates during this period.
 - (3) If odorous gases get into your eyes or are inhaled, immediately wash your eyes with water or gargle.
 - (4) Do not lick the electrolyte of the product. If the electrolyte gets on your skin, then wash it off with soap.
 - (5) When a current value after the short of the product is extremely large, the shorted capacitor may spark out, which, in the worst scenario, may result in ignition. Ensure the safety of the circuit by, for example, giving it a redundant circuit structure or providing it with a protective circuit.

Reliability and product life

The failure rate of the capacitor is specified based on 0.5%*/1000 h (reliability level 60%), a failure rate conforming to JIS C 5003 (failure rate level). This indicates that the possibility of occurrence of a failure is by no means zero. One of the failure modes is a wear out failure. This happens when the period of guaranteeing the durability and high-temperature/high-humidity resistance of the capacitor is over, changes in the electrical characteristics of the capacitor (product) get larger and its electrolyte gradually deteriorates into an insulating material to create an open mode. Another failure mode is a random failure in which a short mode results mainly because of thermal, electrical, or mechanical stress, etc.

Circuit design and circuit board design

- Due to reasons such as increased leakage currents, do not use this product in high impedance circuits, coupling circuits, time constant circuits, and circuits that are significantly affected by leakage currents.
- During circuit design, be mindful that the electrical characteristics of this product, such as capacitance and ESR, may fluctuate within the specified ranges even under conditions that meet the rated electrical and mechanical performance.
- Leakage currents may increase due to mechanical and thermal stress (soldering, high-temperature no-load test, etc.). However, when the voltage (lower than or equal to the category voltage and upper limit temperature) is applied, leakage currents gradually decrease due to the self-recovery function.
- If an excessive rush current flows due to rapid charging and discharging, then it may lead to short circuits and increased leakage currents. Therefore, apply a protection circuit to this product if the rush current value flowing through it is as follows.
 - (1) When a rush current of 10 A or more flows through a product whose tenfold allowable ripple current is less than 10 A.
 - (2) With regard to a product whose tenfold allowable ripple current is 10 A or more, when a rush current exceeding the tenfold value flows through the product.
- The resin on the surface of the case does not guarantee insulation. In addition, there is an indefinite resistance between the case and the cathode terminal, and they are not insulated. Therefore, completely isolate the case from the cathode terminal, anode terminal, and circuit pattern.

Mounting and storage conditions

- Soldering with a soldering iron
 - (1) Since the lead wire pitch dimension of the radial lead type capacitor and the printed circuit board hole pitch dimension do not match, when processing the lead wires, do not apply stress to the body before soldering.
 - (2) When soldering, do not apply excessive stress to the body of this product.
 - (3) Once the product has been soldered, when using a soldering iron to remove it, remove it after the solder has completely melted so as not to apply stress to the electrode terminals of the product.
 - (4) Do not allow the tip of the soldering iron to touch the body of this product.

■ Flow soldering

- (1) Do not apply flow soldering to the surface mount type model of this product.
- (2) Do not solder this product by immersing its body in molten solder.
- (3) Solder only on the opposite side of the circuit board surface where this product is mounted.
- (4) Do not allow flux to adhere to parts other than the electrode terminals.
- (5) Do not allow other parts to fall over and come into contact with this product during soldering.

■ Reflow soldering

- (1) Do not apply reflow soldering to the radial lead type model of this product.
- (2) Please contact us separately for soldering conditions for using the VPS method.

■ Handling after soldering

Observe the following precautions to avoid applying excessive stress on this product.

- (1) Do not tilt, knock over, or twist this product.
- (2) Do not move the circuit board by grabbing this product.
- (3) Do not hit this product with objects.
- (4) When stacking circuit boards, do not allow circuit boards or other parts to come in contact with this product.

- It is recommended that all components in the bag be used up by opening the bag immediately before use. However, if the remaining components are to be stored after opening the bag, please use them up within the following specified period* to maintain good solderability.

* The surface mount type does not comply with the JEDEC J-STD-020 specification.

- | | |
|---------------------------------------|------------------------------------------------------------------------------------------------------------------|
| (1) Surface mount type | : Within 24 months after shipment (before opening) and within 30 days after opening (packaged with carrier tape) |
| (2) Radial lead type (bagged product) | : Within 30 months after shipment (before opening) and within 7 days after opening |
| (3) Radial lead type (taped product) | : Within 24 months after shipment (before opening) and within 7 days after opening |

Reference information

Intellectual property

Panasonic Group provides customers with safe products and services. We are also making great efforts to protect our intellectual property rights for Panasonic Group products. Typical patents related to this product are as follows.

[U.S. patent]

USP No. 7158367