

## 12 mm Square GS Encoders with Push-on Switch

Type: **EVEJB**

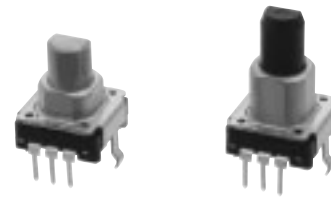

### ■ Features

- Thin type encoder with vertical push-on switch
- Insulated shaft or metal shaft types are available

### ■ Recommended Applications

- Volume and tone control for audio/visual and car audio equipment
- Tuner for communication units

### ■ Explanation of Part Numbers

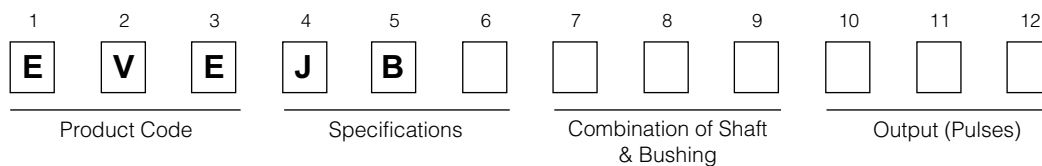

### ■ Specifications

Mechanical	Rotation Angle		360 ° (Endless)
	Shaft Pull/Push Strength		80 N min.
	Shaft Wobble		0.7xL/30 mm max.
	Rotation Torque		3 mN·m to 20 mN·m
	Detents		20 points
Electrical	Output Signals		Phase A and B
	Resolution		20 pulses/360 °
	Rating		1 mA 10 Vdc
	Contact Resistance		1 Ω max.
	Chattering		2 ms max.
	Insulation Resistance		10 MΩ min. (at 50 Vdc)
	Dielectric Withstanding Voltage		50 Vac for 1 minute
	Bouncing		5 ms max.
Switch Part	Type		SPST Push-on
	Rating		20 mA 16 Vdc
	Contact Resistance		100 mΩ max.
	Operating Force		3 N, 6 N
	Travel		0.4 mm
Endurance	Operating Life	Encoder	30000 cycles min.
		Switch	15000 cycles min.
	Operating Temperature		-10 °C to +60 °C
	Storage Temperature		-40 °C to +85 °C
Minimum Quantity/Packing Unit			100 pcs. Polyethylene Bag(Bulk)
Quantity/Carton			500 pcs.

Design and specifications are each subject to change without notice. Ask factory for the current technical specifications before purchase and/or use. Should a safety concern arise regarding this product, please be sure to contact us immediately.

### ■ Dimensions in mm (not to scale)

● Standard rotation-torque / Bushing Type with Sleeve / with Switches .....With detents : EVEJBB

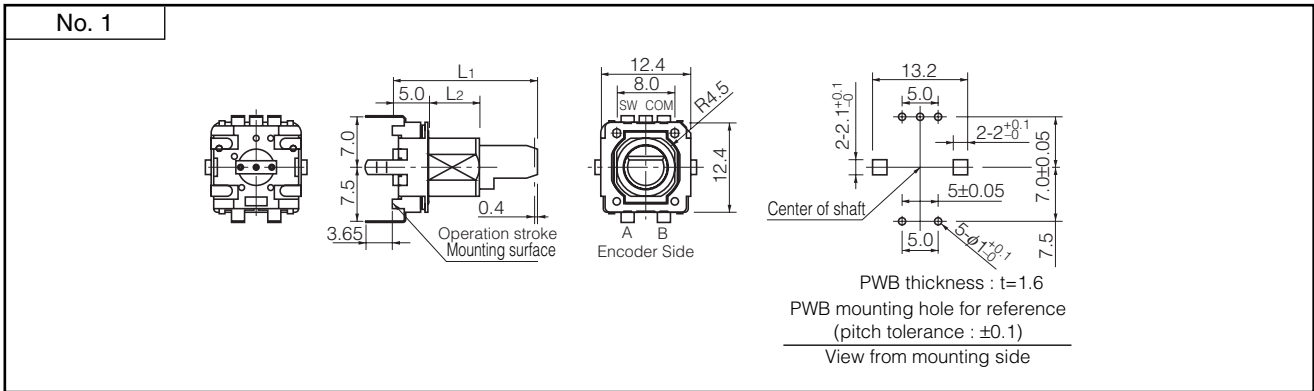

● Standard rotation-torque / Bushing Type with Sleeve / with Switches .....With detents : EVEJBE

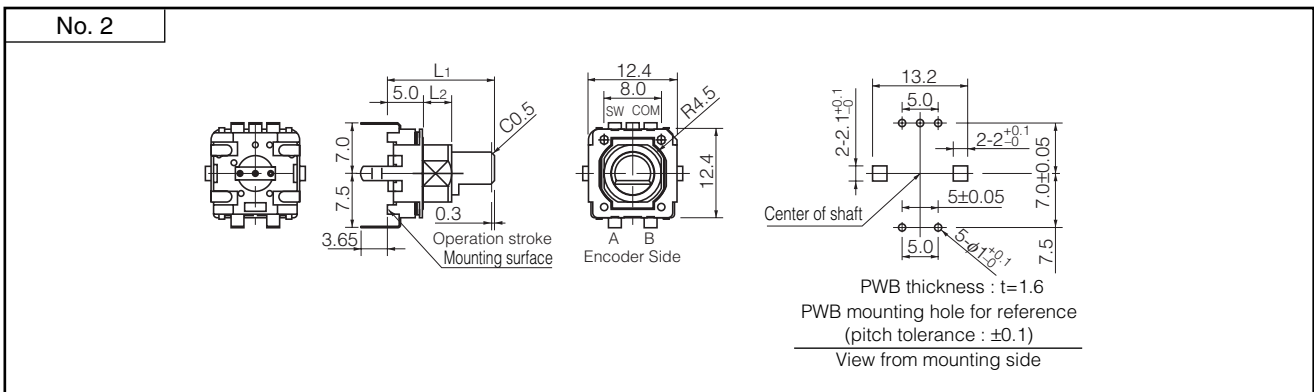

### ■ Shaft Trims and Dimensions in mm

Shaft Type	Dimensions			
	$L_1$	$L_2$	$L_3$	Corner Cut
Metal	15.0 mm	4.0 mm	5.0 mm	0.5 mm
Insulated	20.0 mm	7.0 mm	6.0 mm	1.5 mm
	25.0 mm	9.0 mm	10.0 mm	1.5 mm

Diagram showing shaft trim dimensions:  $L_1$ ,  $L_2$ ,  $L_3$ ,  $4.5_{-0.1}$ , and  $\phi 6.0_{-0.1}$ . A "Corner Cut" is indicated on the shaft.

### ■ Phase Difference

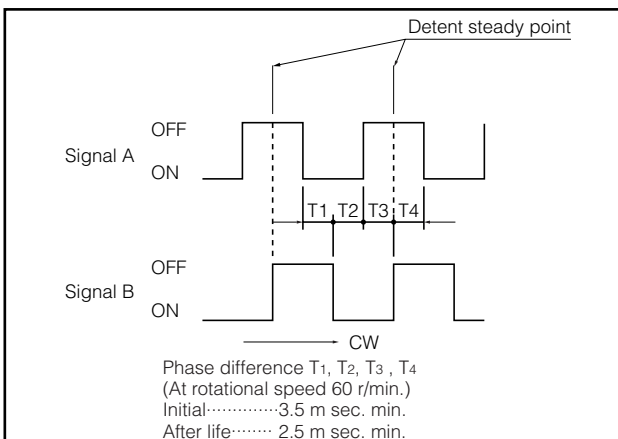

### ■ Test Circuit Diagram

