

8 mm Square Long Travel SMD Light Touch Switches

Type: **EVQQ1**



■ Features

- External dimensions : 8.5 mm×8.5 mm, Height 6.5 mm (Including the push plate)
- High operating force which prevents incorrect operation
- Reliable contact (dust-proof design)

■ Recommended Applications

- Operating switches for car electronic equipment, car audio systems, etc.
- Steering switches

■ Explanation of Part Numbers

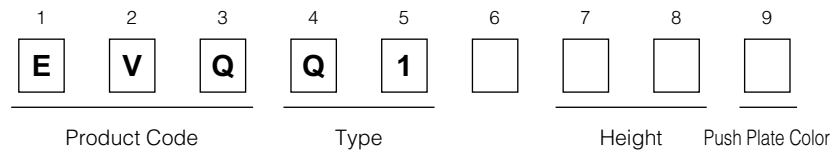

■ Specifications

Type	Snap action/Push-on 1-pole 1-throw SPST	
Electrical	Rating	10 μ A 2 Vdc to 50 mA 12 Vdc (Resistive load)
	Contact Resistance	100 m Ω max.
	Insulation Resistance	100 M Ω min. (at 100 Vdc)
	Dielectric Withstanding Voltage	250 Vac for 1 minute
	Bouncing	10 ms max. (ON, OFF)
Mechanical	Operating Force	4 N, 5 N
	Travel	1.0 mm
Endurance	Operating Life	100000 cycles min.
Operating Temperature		-40 °C to +85 °C
Storage Temperature		-40 °C to +85 °C (Bulk) -20 °C to +60 °C (Taping)
Minimum Quantity/Packing Unit		1000 pcs. Embossed Taping (Reel Pack)
Quantity/Carton		10000 pcs.

■ Dimensions in mm (not to scale)

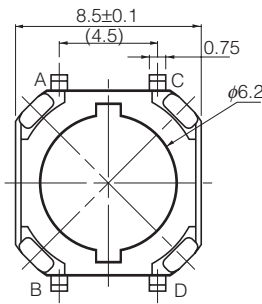
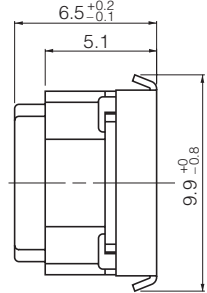
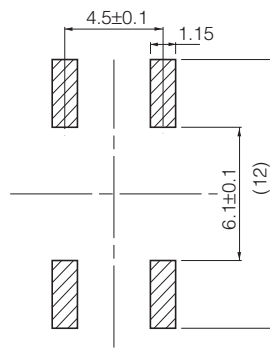
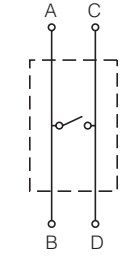
<p>EVQQ1 (Embossed Taping)</p> 		
		
		
	 <p>Circuit diagram</p>	
Part Numbers	Operating Force	Push Plate Color
EVQQ1D06M	4.0 N	Natural
EVQQ1E06K	5.0 N	Black

■ Recommended Reflow Soldering Conditions

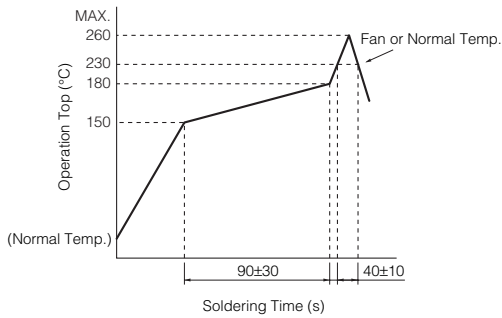

● Embossed Carrier Taping

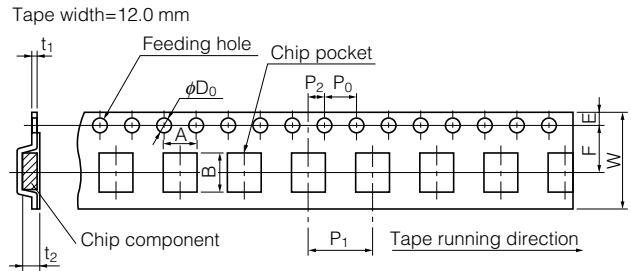

Part No.	Height	A	B	W	F	E	P ₁	P ₂	P ₀	D ₀ Dia.	t ₁	t ₂
EVQQ1	6.5	8.9±0.2	10.1±0.2	16.0±0.3	7.5±0.1	1.75±0.10	12.0±0.1	2.0±0.1	4.0±0.1	1.5 ^{+0.1} ₀	0.40±0.05	6.8±0.2

Unit: mm

● Standard Reel Dimensions in mm (not to scale)

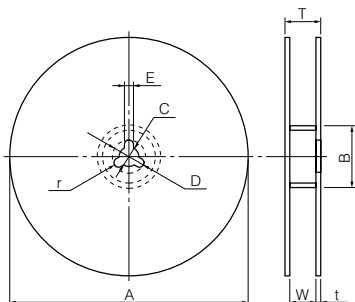

Item	A	B	C	D	E
Rate (mm)	φ380.0±2.0	φ80.0±1.0	φ13.0±0.5	φ21.0±1.0	2.0±0.5

Item	W	T	t	r
Rate (mm)	17.5±0.5	21.5±1.0	1.0 to 3.0	1.0±0.5