

Wirewound Resistors, Flameproof, Bath-tub Type (High Power with Aluminum Case Type)

Type: **ERF□□□W**

ERF60W, ERF100W, ERF150W, ERF200W



■ Features

- FlameproofMade from nonflammable materials, making the resistor very safe.
- Exclusive Pulse.....Suited for regeneration resistance, due to a structure and materials equipped for pulse characteristics.
- Uniform Quality.....An exclusive automated process with a meticulous quality-control system, combining fine selections of resistance wires and associated qualified materials resulting in uniform quality and consistent reliability.

RoHS compliant

■ Explanation of Part Numbers

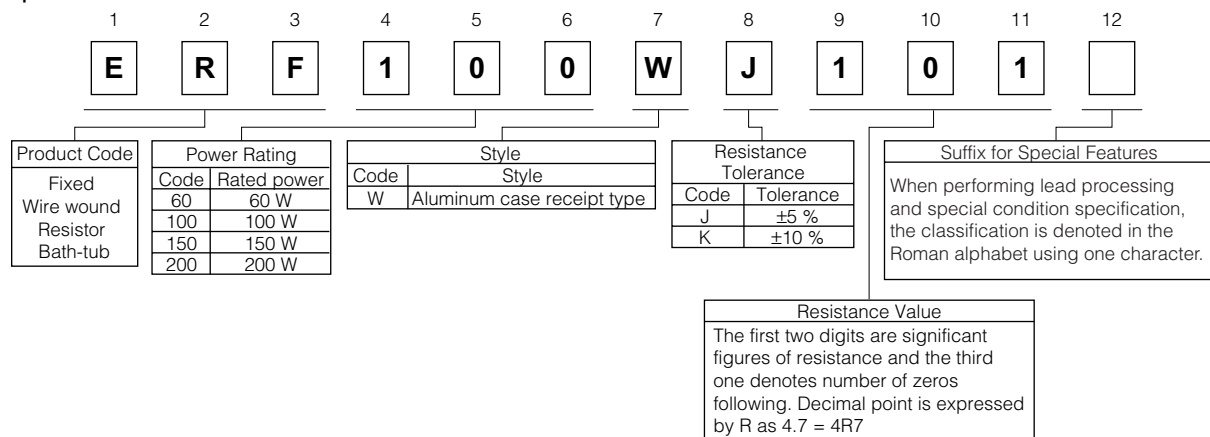

■ Construction

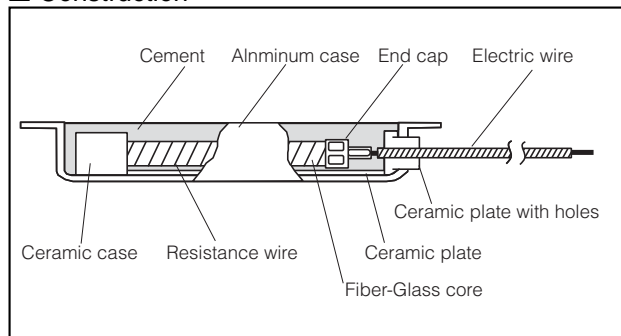

■ Dimensions in mm (not to scale)

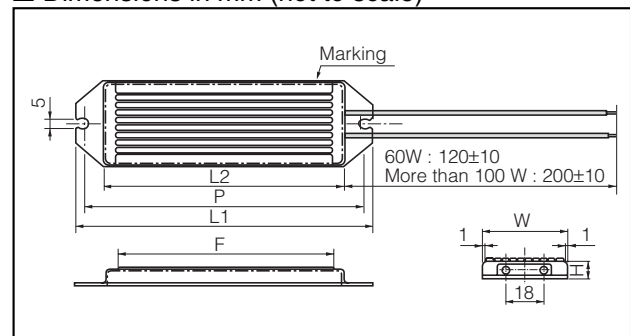

■ Ratings

Type	Power*1 Rating at 25 °C (W)	Resistance Range (Ω)		Dielectric Withstanding Voltage (VAC)	Standard Quantity (pcs.)
		min.	max.		
ERF60W	60	1.2	450	2000	50
ERF100W	100	8.2	910	2000	50
ERF150W	150	11.0	1.2 k	2000	50
ERF200W	200	15.0	1.6 k	2000	50

*1 ; Classis Mounted (300×300×2t Al plate)

Type	Dimensions (mm)						Standard Mass (Weight) (g/pc.)
	L1	L2	W	H	P	F	
ERF60W	100	75	30	13	90	67	58
ERF100W	152	120	44	13	140	112	126
ERF150W	182	150	44	13	170	134	152
ERF200W	230	200	44	13	220	184	183

■ Packaging Methods

Please contact the factory for packaging methods

Design and specifications are each subject to change without notice. Ask factory for the current technical specifications before purchase and/or use. Should a safety concern arise regarding this product, please be sure to contact us immediately.

Safety Precautions

The following are precautions for individual products. Please also refer to the common precautions shown on page 4 of this catalog.

1. Since Wirewound Resistors (hereafter called the resistors) generate heat during use, mount them on your product and carefully check the effect of heat on other components. Provide for adequate safety when designing your product. Otherwise, when a short circuit or other abnormality occurs, or when a voltage or current exceeding the rating is applied, the resistors may overheat without breaking, or may generate smoke or red-heat, breaking the ceramic case and thus exposing the red-heating resistor element.
2. Carefully check the inductance effect of the resistors when using them in a high-frequency circuit.
3. If a transient load (heavy load in a short time) like a pulse is expected to be applied, check and evaluate the operations of the resistors when installed in your products under the most adverse conditions before use.