

- High Speed Fluid Bearing

Standard Dimensions(mm)

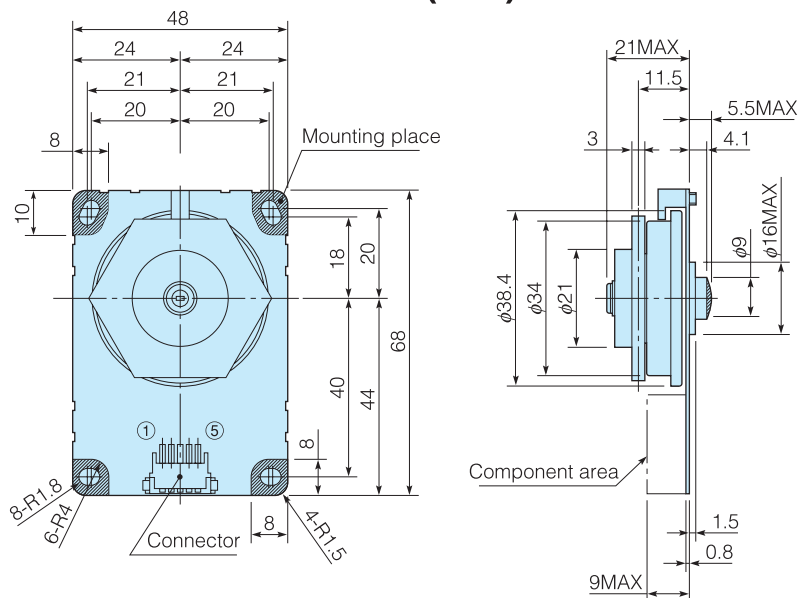

Typical Data

Model	Rated Voltage (V)	Rated Speed (min ⁻¹)	Standard Mirror	Starting Time (S)	Starting Current (A)	Rated Current (A)	Jitter(%p-p) LF RF	Pyramid error(Second) Total Adjacent	Plane	Reflection (%)
MASQ6DF-H	24±10%	32000 (15000 to 38000)	6 Surface 34.64 Inscribed circle	4	1.3	0.6	0.020 0.010	100 50	$\lambda/4$	80