

Linearity Coils (Low vibration and low leakage flux series)

Type: **6700, 7700, 8100, 8500**

Singapore
Indonesia
Brazil

Ideal for horizontal circuitry operated at a minimum of 150AT

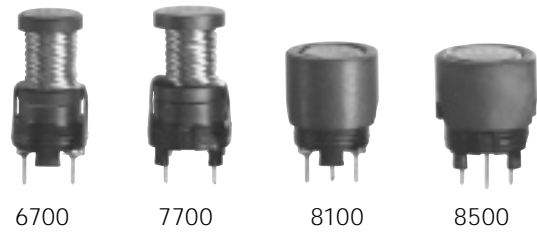

■ Features

- Mechanical vibration (80 % less compared to our conventional type)
- Leakage flux (90 % less (ELH5L8000 type) compared to our conventional types)

■ Recommended Applications

- Digital TVs, Wide screen TVs, Big screen TVs, Displays

■ Explanation of Part Numbers

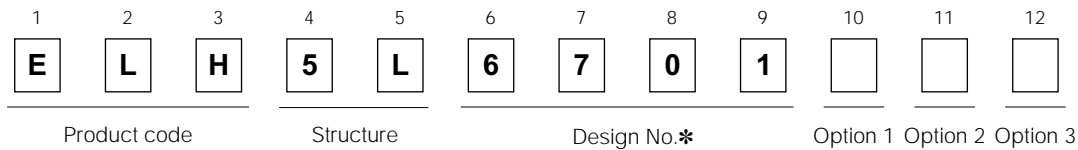

*: When partly omitted, the rest of the P/N factors should be moved up accordingly.

■ Use range

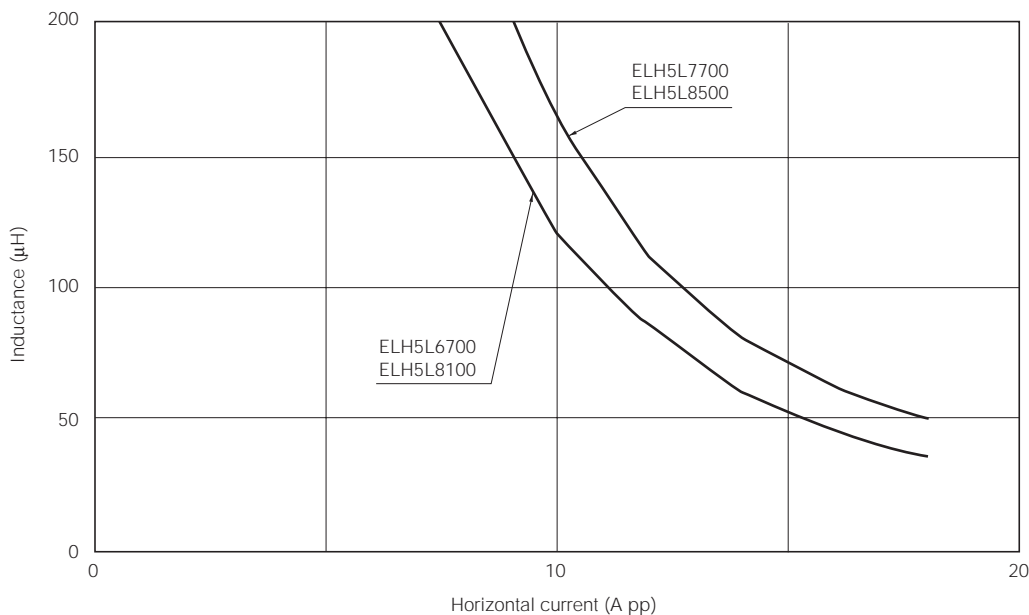

Leakage Flux (Reference)

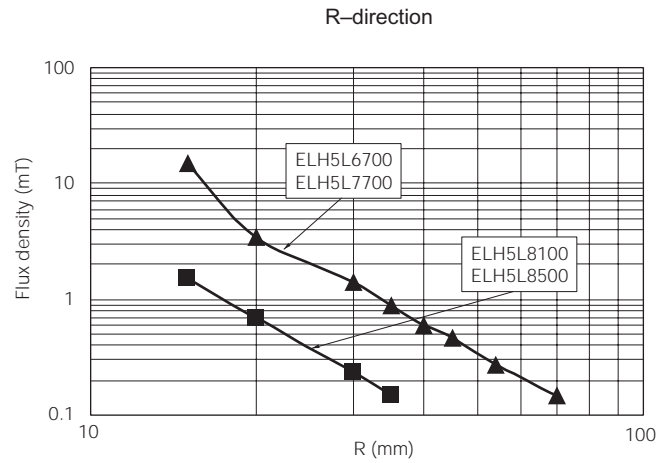
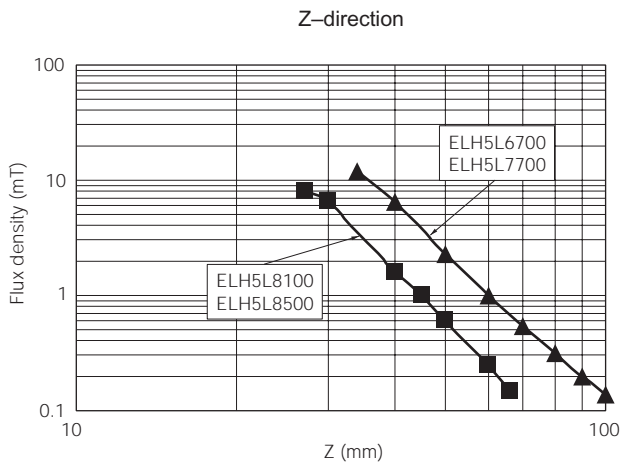

Vibration Levels (Reference)

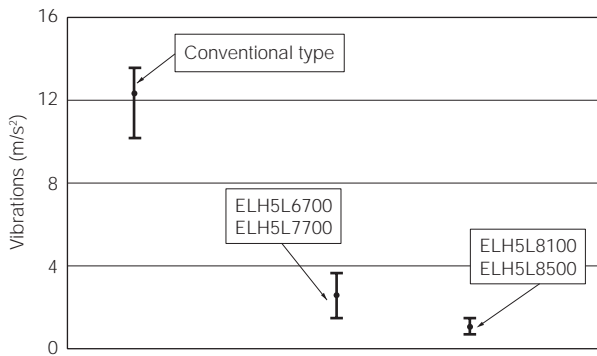

Connection Schematic

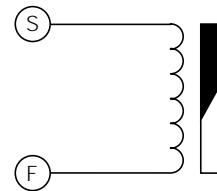

Dimensions in mm (not to scale)

● TYPE 6700

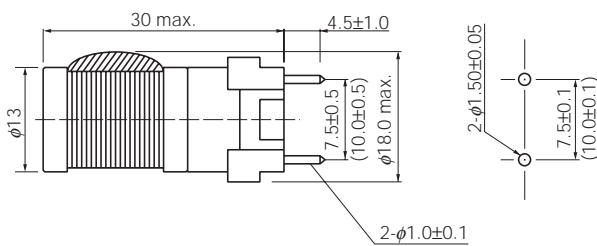

● TYPE 8100

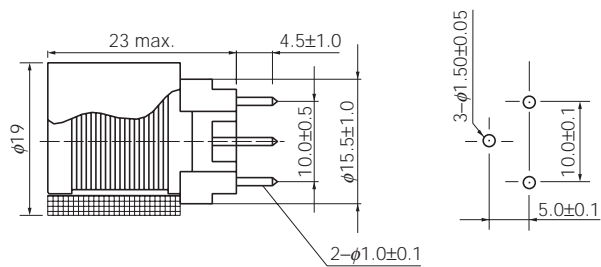

● TYPE 7700

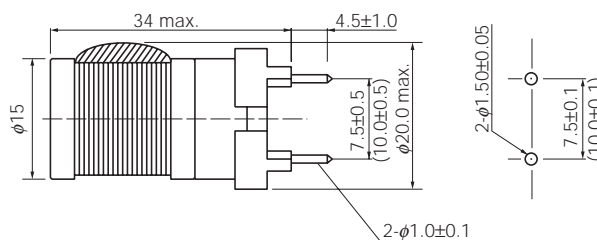

● TYPE 8500

