

SAFETY DESIGN

- **Valve (One way valve)**

If the internal pressure of the battery is raised to an abnormal level, the rubber one way valve opens to release excessive pressure; thus the vent protects the battery from danger of bursting. Since the rubber valve is instantly resealable, the valve can perform its function repeatedly whenever required.

- **Example of Valve Construction**

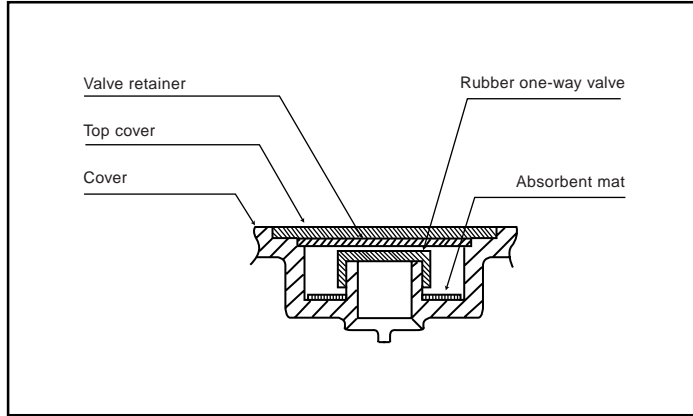

SAFETY

VRLA battery safety test items

Item	Test method	Check point
1. Shock test (Drop test)	A fully charged battery is allowed to drop in the upright position from the height of 20 cm onto a hard board having a thickness of 10 mm or more. Test is repeated three times.	The battery should be free from noticeable breakage or leaks; and its terminal voltage should be held higher than the nominal voltage.
2. Vibration test	A vibration frequency 1000 times/minute and amplitude 4 mm is applied to the X-, Y- and Z-axis directions of a fully charged battery for 60 minutes respectively.	No battery part should be broken; the battery should be free from leaks; and its terminal voltage should be held higher than the nominal voltage.
3. Oven test	A fully charged battery is left standing in an atmosphere of 70°C for 10 hours.	The battery case should not be deformed; the battery should be free from leaks.
4. Coldproof test	A fully charged battery is connected to a resistor equivalent to 60 hour rate discharge and left for 4 days; then the battery is left standing in an atmosphere of -30°C for 24 hours.	No crack should develop in the battery case; the battery should be free from leaks.
5. Heat cycle test	A fully charged battery is exposed to 10 cycles of 2 hours at -40°C and 2 hours at 65°C.	No crack should develop in the battery case; the battery should be free from leaks.
6. Short circuit test	A fully charged battery connected with a small resistor of 10 ohms or less is allowed to discharge.	The battery must not burn nor burst.
7. Large current discharge test	A fully charged battery is allowed to discharge at 3CA to 4.8V / 6V battery level.	The battery must not burn nor burst, and it should be free from battery case deformation, leaks and any irregularity in the internal connections.
8. Vent valve function test	A fully charged battery is submerged in liquid paraffin in a container, then overcharged at 0.4 CA. (UL1989)	Release of gas from the vent should be observed.
9. Overcharge test	A fully charged battery is overcharged at 0.1 CA for 48 hours, left standing for one hour, and allowed to discharge at 0.05CA to 5.25V / 6V battery level.	No irregularity should be noticed in the battery appearance; the battery should retain 95 % or more of the initial capacity.

(Note) The above safety notes apply only to standalone batteries, not to embedded batteries.