

2. Principles and Features of Gold Capacitors

2-1 What are electric double layer capacitors?

Generally, capacitors have dielectric between two opposite electrodes. For example, Aluminum Electrolytic Capacitors use an aluminum oxide film, and Tantalum Capacitors use a tantalum oxide film as dielectric.

However, the electric double layer capacitor does not have dielectric but uses a physical mechanism that generates an electric double layer which performs the function of dielectric, hence, the name Electric Double Layer Capacitor. The charge-discharge factor in the element of electric double layer capacitors is an ion absorption layer which is formed on the surface of the positive and negative electrodes of activated carbon, to utilize absorption-desorption reactions.

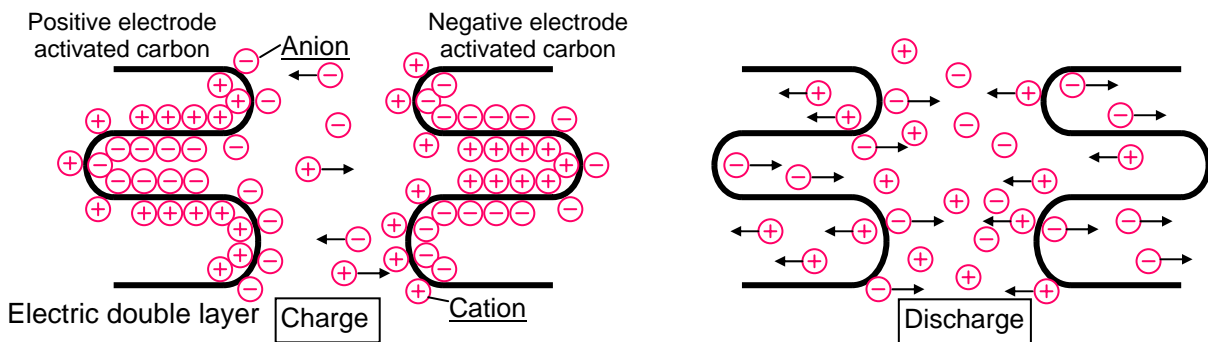

(Fig.1)

In an electric double layer capacitor, there are two types of electrolyte systems used. One is water soluble and the other is non-water soluble. The non-water soluble electrolyte can increase the withstand voltage per one cell compared to water soluble electrolyte. Our Gold Capacitors are constructed with non-water soluble electrolyte, and feature small size and light weight.

The capacitance range of Gold Capacitors is mid-range between aluminum electrolytic capacitors and a secondary battery. For application, it is mainly used as a secondary battery.

Capacitance [Farad]	10^{-6}	10^{-4}	10^{-2}	10^0	10^2	10^4	10^6
Aluminum electrolytic capacitor	→						
Gold capacitor			↔				
Secondary battery cell				→			

The benefits of Gold Capacitors are small size and high capacitance. Gold Capacitors are used to backup the real-time clock or memory as substitutions for secondary batteries. The examples are RTC backup of DVD, fax, telephone, DSC, mobile phone and stereo. Recently, Gold Capacitors are in the spotlight as a hybrid power supply system by the combination with the solar cell.

2-2 Construction and principle of electric double layer capacitors

A cross-sectional drawing of a coin- shaped single cell Gold Capacitor is shown in Fig.2.

The electrode within the cell is made from activated carbon. The electrode is then impregnated with an electrolyte. A separator with high insulating properties against ion penetration is positioned between both electrodes to prevent short circuiting. Sealing is completed by adding packing between the top cover and bottom case.

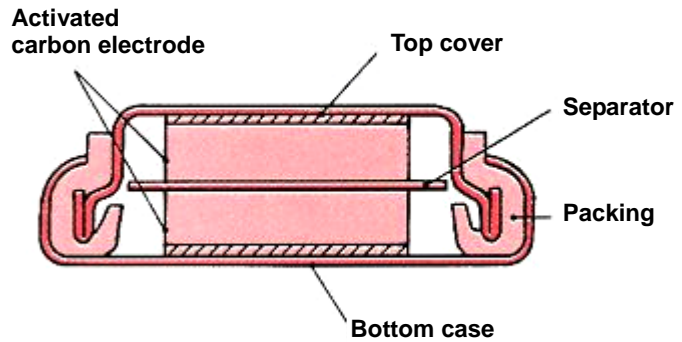

(Fig.2)

An electric double layer is a state where a very thin ionosphere is formed to the boundary of the electrolyte and the electrode (Shown in Fig.3.). Electric charge can be charged by applying the voltage (shown in Fig.4.)

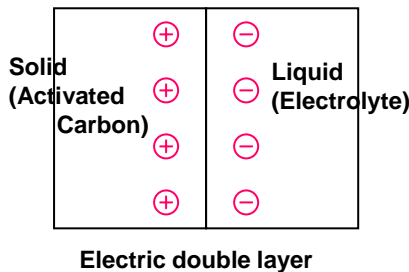

(Fig.3)

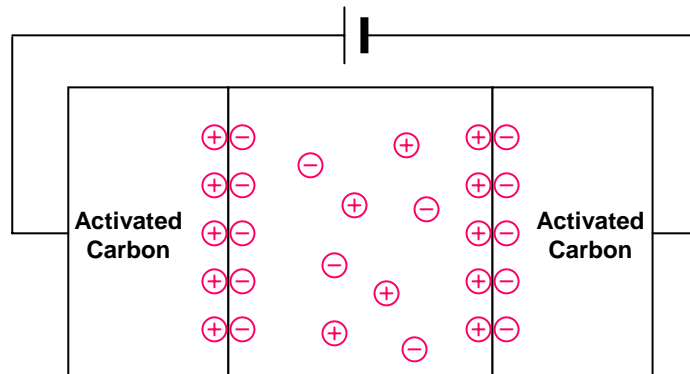

(Fig.4)

The electric double layer acts as an insulator and does not allow current flow when an external DC voltage is applied. However, as the voltage is increased, an avalanche point is reached and current will begin to flow. The magnitude of this voltage is the “decomposition voltage”. Further increasing this voltage will cause the electrolyte to decompose causing additional current flow. The withstand voltage of Gold Capacitors is determined by the decomposition voltage. The decomposition voltage is decided with electrolyte and electrode material that composes Gold Capacitors.

Gold capacitors use an activated carbon electrode (solid) and an organic electrolyte (liquid). Electric double layer formed to the interface of the electrode and electrolyte is very thin like a molecule. The activated carbon used for the electrode is a very large surface. Therefore, it becomes very high capacitance. Panasonic uses high withstand voltage organic electrolyte and products can be miniaturized.

2-3 Equivalent circuit

The same equivalent circuit used for conventional capacitors can also be applied to Gold Capacitors.

In an electric double layer capacitor, the electric double layer is formed on the surface of the activated carbon that is in contact with the liquid electrolyte. This is shown in Fig.5.

Because activated carbon particles are used as electrodes, each carbon layers as in Fig.5 functions as an electric double layer capacitor having a capacitance value of C_n . In order for the capacitance C_n to charge, two resistances are needed and are described in Fig.6.

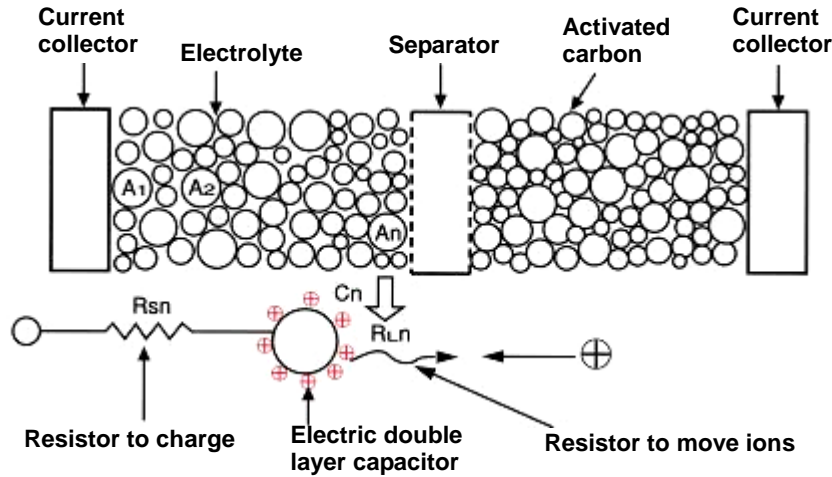

(Fig.5)

As can be seen in Fig.6, resistance R_1 moves ions while resistance R_s is the charging resistance. The double layers formed on the activated carbon surfaces can be shown as parallel circuits.

The resistances values can increase or decrease depending on the distance between the current collectors, speed of ions, contact resistance between the activated carbons, etc.

The equivalent circuit of an electric double layer capacitor is shown by the parallel R-C combinations shown in Fig.7.

R_1 , R_2 and R_n are the internal resistance of the activated carbons. C_1 , C_2 and C_n are the capacitance of the activated carbons having resistances R_1 , R_2 and R_n .

When applying a simple CR series circuit, the charging current (i) when the voltage

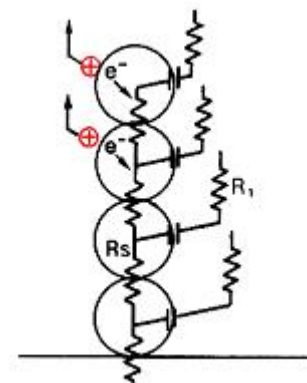

Particle type activated carbon

(Fig.6)

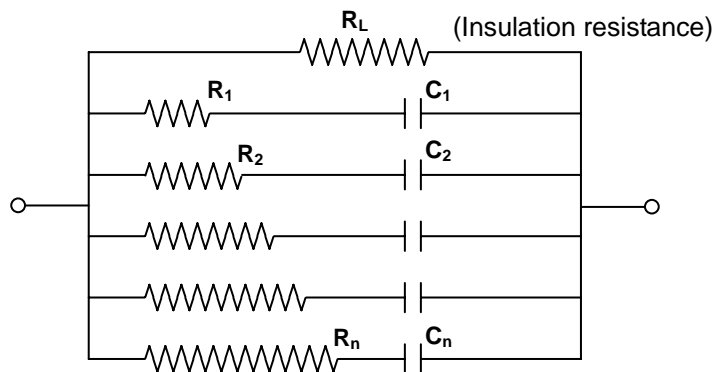

(Fig.7)

(V) is applied decreases according to formula-(1). The value of the charging current decreases at charging time(t) . However, the actual charging current curve is exponential.

$$i = \frac{V}{R} \exp\left(\frac{-t}{C R}\right) \quad (1)$$

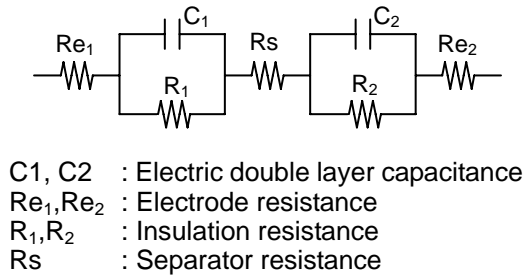

(Fig.8)

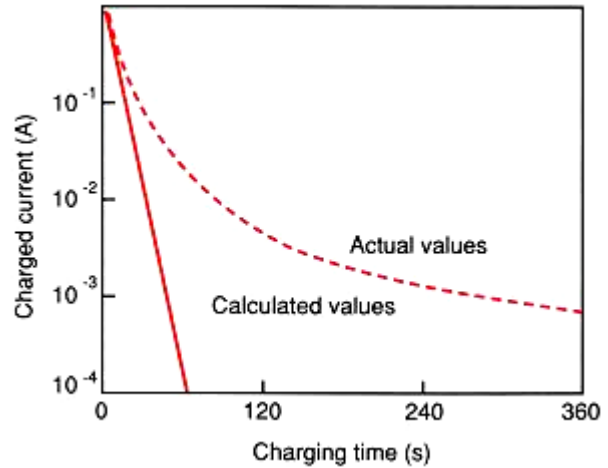

(Fig.9)

If one considers the equivalent circuit of the electric double layer capacitor shown in Fig.8 as having many small capacitors (C_n) with various internal resistances (R_n), then the current that flows through an individual capacitor can be represented by formula-(2).

$$i_n = \frac{V}{R_n} \exp\left(\frac{-t}{C_n R_n}\right) \quad (2)$$

Therefore, the current(i) within the capacitor can be regarded as the sum(Σi_n) of the currents flowing through each of the small capacitors. It also can be seen that if the C×R value is small, the charging time will be short. Conversely, if the C×R value is large, the charging time will be long. The sum of the small capacitor charging currents is shown in Fig.10.

It should be noted that if the charging time is limited to only several minutes, or the charging source is current limited, the Electric double layer capacitor may not be sufficiently charged to provide the required back-up energy for the time needed. If the capacitor is not sufficiently charged and is called upon to discharge its energy into a load, the discharge current will flow from a high voltage level to a low voltage level thereby causing a low terminal voltage. These conditions are shown in Fig.11, 12.

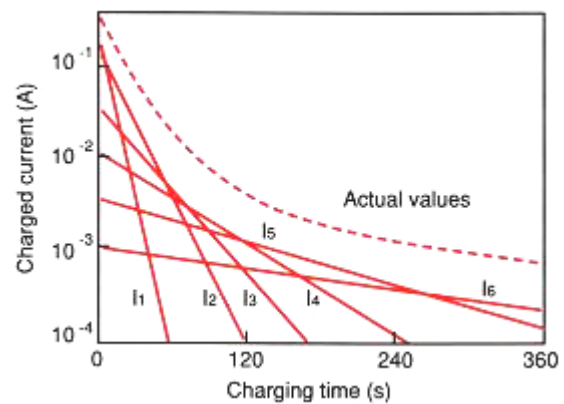

(Fig.10)

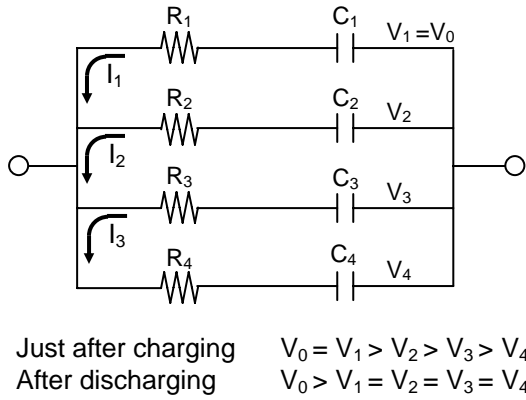

(Fig.11)

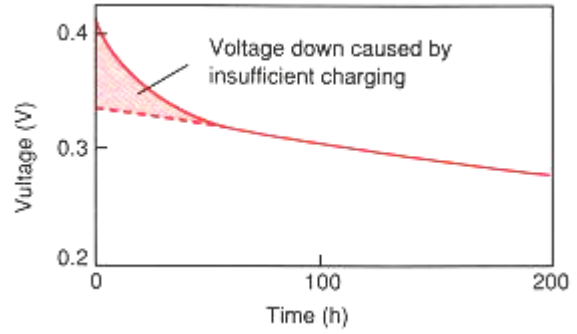

(Fig.12)

2-4 Electrical characteristics of electric double layer capacitors

2-4-1 Capacitance

The capacitance of an electric double layer capacitor differs from the battery and is not influenced by the measurement condition in theory. However, it is influenced by internal resistance and leakage currents. Therefore, the electrical characteristics change depending on the measurement condition.

As previously stated, the electric double layer capacitor is comprised of many small capacitors having various values of resistance. Therefore, in order to measure the capacitance, measurement parameters such as charge voltage and charge time must be defined.

If the starting voltage is set slightly below the fully charged voltage value (V_0), then the voltage down condition shown in Fig.13 will occur at the start of measurement. This is due to the small capacitors that have large internal resistance not being fully charged which results in a large voltage drop at the start of measurement. With this condition, the measured capacitance value will be small.

However, by increasing the charging time, the small capacitors with high resistances will become charged and the voltage lost during the voltage down condition will be small resulting in a high measured value of capacitance. See Fig.13.

In addition, the capacitance is influenced also by the current. Therefore, we use 1mA/F as a standard of the measurement current. (It is discharged by the constant current for each 1F of 1mA.)

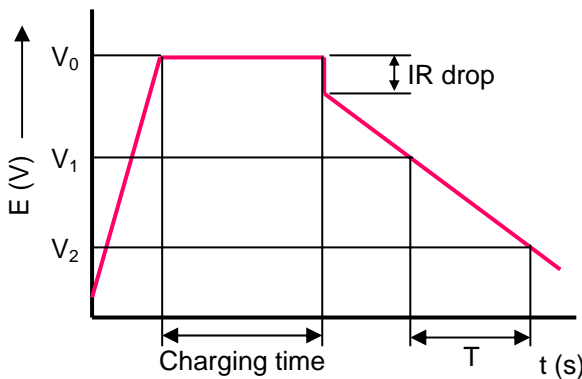

$$C = \frac{I \times T}{(V_1 - V_2)} \quad (\text{Farad}) \quad (3)$$

C : Capacitance(F)
 I : Test current(A)
 T : Test time(s)
 V1 - V2: Testing voltage range(V)

(Fig.13) Electrostatic capacitance test

2-4-2 Internal resistance

As previously described, the equivalent circuit of an electric double layer capacitor consists of many small capacitors having various internal resistance values. Normally, the values of these resistors would be expressed in DC values. However, so that a true picture may be established, we will use impedance (1kHz) as the parameter and being that the DC resistance and Z value are not equal, we must consider their relationship under current conditions.

2-4-3 Current

If current is measured 30 to 60 minutes after the application for rated voltage, quite a large current (several 10μA) will be present. This is due to the fact that the measured current is the sum of the charging currents that is flowing within the many small capacitors shown in the equivalent circuit. As it is extremely difficult to determine the leakage current of electric double layer capacitors, the current value specified as the leakage current is somewhat meaningless. It takes a minimum of 10 hours to fully charge the capacitor so that a meaningful leakage current value can be obtained.

2-4-4 Charging characteristics

The charging characteristics of an electric double layer capacitor can be represented by the equation(4) below:

$$V = V_0 \left\{ 1 - \exp\left(\frac{-t}{CR}\right) \right\} \quad (4)$$

Because of the many internal resistances within the electric double layer capacitor, no external current limiting resistor is needed.

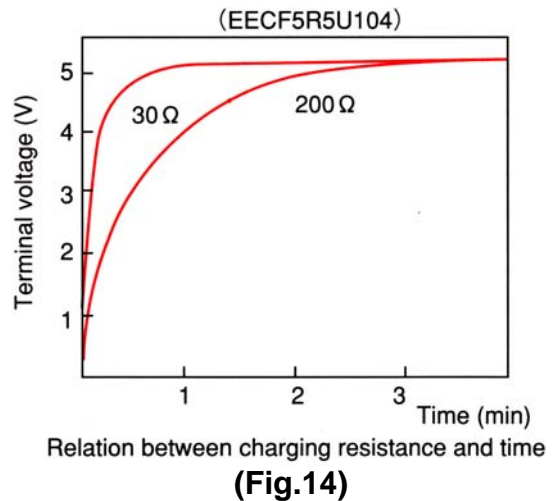

2-4-5 Discharging characteristics

Self discharge characteristics

The self discharge characteristic of an electric double layer capacitor is shown in equation (5).

$$V = V_0 \exp\left(\frac{-t}{C R_L}\right) \quad (5)$$

RL: Insulation resistance

This Fig.15 shows ideal self-discharge in the state that the product is completely charged. The self-discharge changes actually by the influence at charging time.

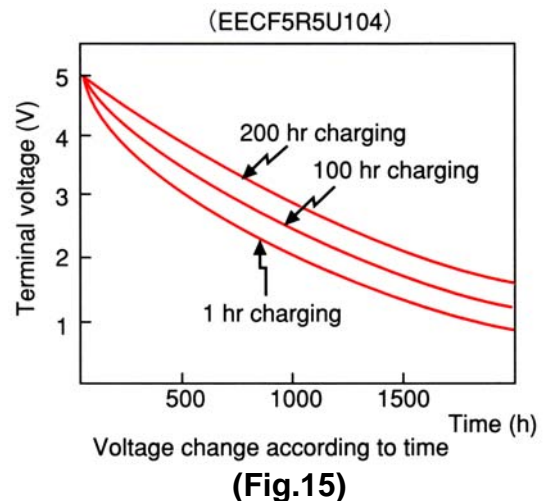

Characteristics of constant current and constant resistance discharging

The time required for the constant current and constant resistance discharging are respectively presented by the equations (6) and (7) below

Discharging time (t) of constant current discharge

$$t = \frac{C(V_0 - V_1)}{I} \quad (6)$$

Discharging time (t) of constant resistance discharge

$$t = -C R \ln\left(\frac{V_1}{V_0}\right) \quad (7)$$

t : Charging time
C : Capacitance
V₀: Initial voltage
V₁: Terminal voltage after t(s)
I : Constant current load
R : Constant resistance load

The above equations may not always be accurate, as the terminal down voltage must be considered after the start of discharge if load resistance or load current is present.

Backup characteristics for IC

Also, if the capacitor is used to back-up and IC, the V-I characteristics of the IC must also be considered. It can therefore be said that if the voltage is low, the current is also low and the actual back-up time will be longer than that calculated. To be certain that the capacitor selected is of sufficient value to maintain the necessary energy and time, it should be checked and measured under actual operating conditions.

2-5 Features

The capacitance of an electric double layer capacitor can be expressed by equation (8)

$$C \propto \frac{S}{d} \quad (8)$$

d = thickness of electric double layer

s = area of an activated carbon

It should be noted that the area of an activated carbon is approximately 2500 cm²/gram and the thickness of a double layer is less than a molecule. From this, it can be readily seen that the capacitance of an electric or double layer capacitor is several times greater than of an aluminum electrolytic capacitor.

The internal resistance of an electric double layer capacitor is quite high compared to an aluminum electrolytic capacitor and because of this it should not be used as a filter in an AC application. These devices are specifically designed for energy back-up applications and secondary power sources.

Wide range for each application

These are wide range of Gold Capacitors from the coin type which is primarily used as RTC back-up to the HW series which need large current.

Limited life

Gold Capacitors have a limited life .

However, they have a capability that can be fully used within the life of equipment when used under the proper conditions. (Refer “the Life” in details)

Therefore, you don't need to replace the battery. Also, in overseas, there are many regulations for batteries. It can be said Gold Capacitors are the best source for use in overseas.

Wide operating temperature range

Compared to Gold Capacitors, batteries lose much of their energy with exposure to heat and are susceptible to leakage with exposure to temperatures below 0°C. Gold Capacitors are suitable where the operating temperature conditions are need to be considered, such as automobile stereo set for import, etc.

No need of charge control

Secondary batteries generate heat for over-charge and discharge, which make the life shorter. A charge control circuit is needed. However, Gold Capacitors have no limit for charge and discharge and do not need a charge control.

Speed charge, repeated charge/discharge cycles

Speed charge is possible for Gold Capacitors. Repeated rapid charge and discharge cycles are acceptable because there is no internal chemical reaction like batteries. It suits the circuit that repeats charge and discharge for a short time, which can not take a long charge time.

Good for environmental as secondary source

There are no toxic materials such as cadmium, mercury in Gold Capacitors. Europe has recently restricted the use of products containing toxic materials due to pollution, and this action will be expanded. Our Gold Capacitors do not use cadmium and mercury. And LED lights using our Gold Capacitors are very popular for clean energy applications in Europe. Thus, Gold Capacitors are suitable for Europe and America where the restriction will be stricter.