

Performance & dimensions

Appearance - representative

Rated voltage / Frequency	Model		Dimension -mm			Mount	
	Name	Cooling type	A	B	C	Dia.-mm	Pitch-mm
115V 60Hz	SHH48C97RAU	ST / FC	151.2	170	172.5	Ø16 * 4	70 * 170
	SHH51C97RAU					Ø19 * 4	101.6 * 165.1

Note) Compressor cooling: ST = Static cooling, FC = Fan cooling, OC = Oil cooling

Tube dimension - representative

Rated voltage / Frequency	ID / OD -mm				Location of
	Dis.	Suc.	Pro.	Oil cooler	Suction tube
115V 60Hz	4.9 / 7.0	6.5 / 8.3	6.5 / 8.3		Terminal side

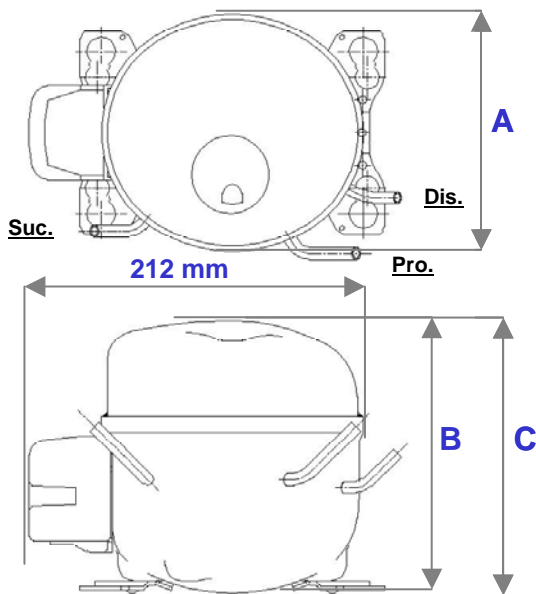

115V 60Hz