

*Using breakthrough technology,  
we aim for products that will create new markets.*

## *New Product News*

Wide range of products

### Switches

#### 4 mm Square Double-Action Light Touch Switch

Industry/Field: Optical equipment, Information and AV equipment

\*Note 1

### Long-life two-stage operation switches with the smallest switch size in the industry.

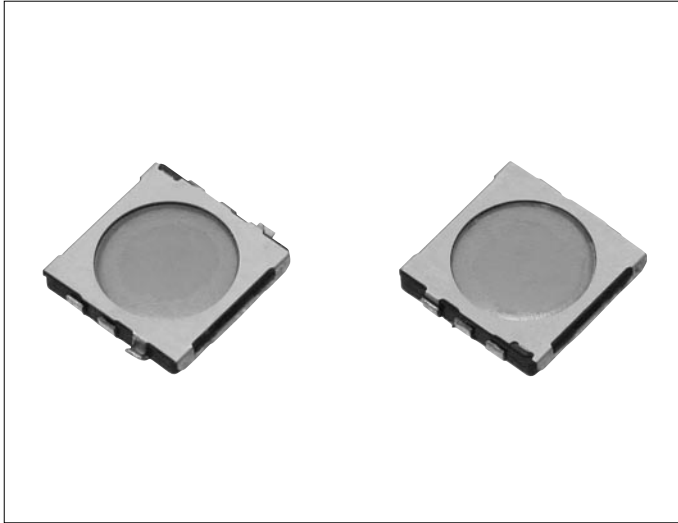

#### • Development Target:

A small, low-profile, and long-life two-stage operation switch has been developed for the shutter switch application of digital still or video cameras, or mobile phone cameras.

#### • Features:

- 1** The smallest switch size in the industry  
External dimensions: 4.0 mm Wide × 4.1 mm Deep × 0.6 mm High
- 2** Long life has been achieved.  
Operating life: 100,000 operations (1.6-N type)
- 3** Provides an operation feel in accordance with the application.

\*Note 1: As of September 20, 2006

#### • Construction:

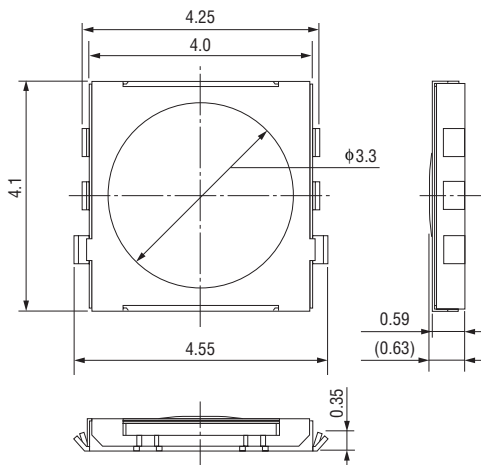

#### • Characteristics/specifications:

Item	Specifications
Rating	20mA 15V dc max.
Contact Resistance	500 mΩ max.
Insulation Resistance	100MΩ min. (100V dc)
Dielectric Withstanding Voltage	250Vac for 1 minute
Bouncing	20ms max. (ON. OFF)
Operating Life (Operating Force)	100000 cycles (1.6N type) 100000 cycles (2.0N type) 50000 cycles (2.6N type)
Travel	1st : 0.15mm 2nd : 0.3mm (first + second)
Operation Temperature	-20°C to +70°C (45% to 85% RH)

#### • Applications/usage examples:

- Auto-focus and shutter release functions for digital still and mobile phone cameras

#### • Explanation of part numbers:

1	2	3	4	5	6	7	8	9
E	V	P	A	H				
Product code			Type		Height/ Packing			