

# Dimensions of Motor with Gear Reducer

## ● MUMA series with gear reducer

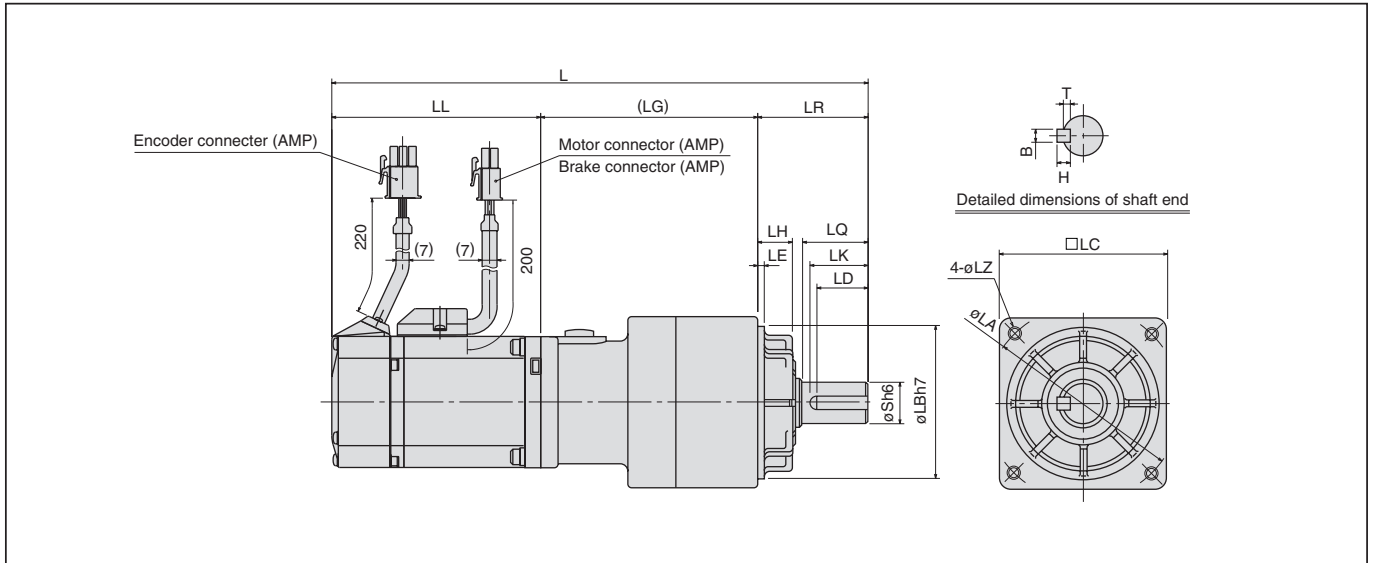

## ● 2500P/r encoder

[unit: mm]

Model	Motor output	Reduction ratio	L	LL	LR	LQ	LC	LB	LA	S	LH	LZ	LK	(LG)	LE	Key way (BxHxLD)	T												
MUMA01□P□1N	100W	1 / 5	192	92.5	32	20	52	50	60	12	10	M5 (Depth : 12)	18	67.5	3	4X4X16	2.5												
MUMA01□P□2N			223.5	124																									
MUMA01□P□4N		1 / 9	192	92.5																									
			223.5	124																									
MUMA02□P□1N	200W	1 / 5	200.5	96	50	30	78	70	90	19	17	M6 (Depth : 20)	26	92		6X6X22	3.5												
			MUMA02□P□2N	234.5														124											
MUMA02□P□4N		1 / 9	235.5	96																									
			268.5	129																									
MUMA04□P□1N		400W	1 / 5	246											96			61	40	98	90	115	24	18	M8 (Depth : 20)	35	104	8X7X30	4
				MUMA04□P□2N											279														
MUMA04□P□4N	1 / 9		263	123.5																									
			296	156.5																									
MUMA04□P□1N	1 / 25		263	123.5																									
			296	156.5																									
MUMA04□P□2N	1 / 25		288.5	123.5																									
			321.5	156.5																									

Upper column : without brake   
 Lower column : with brake