

Standard Wiring Example of Main Circuit

● Frame A, B

• In Case of Single Phase, 100V

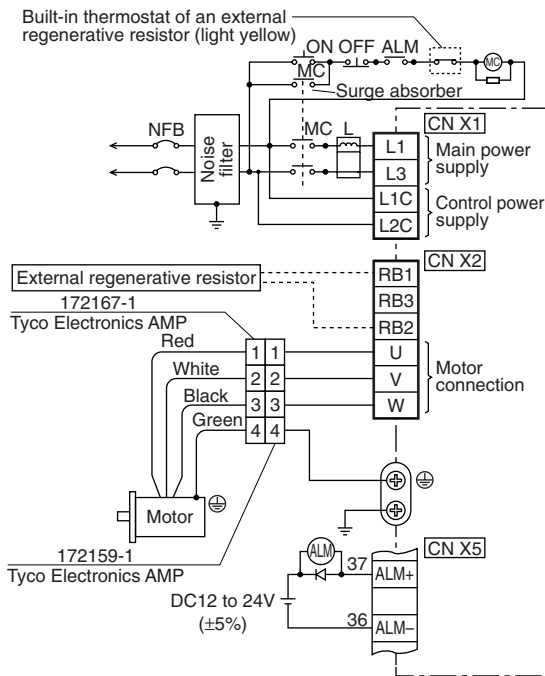

• In Case of Single Phase, 200V

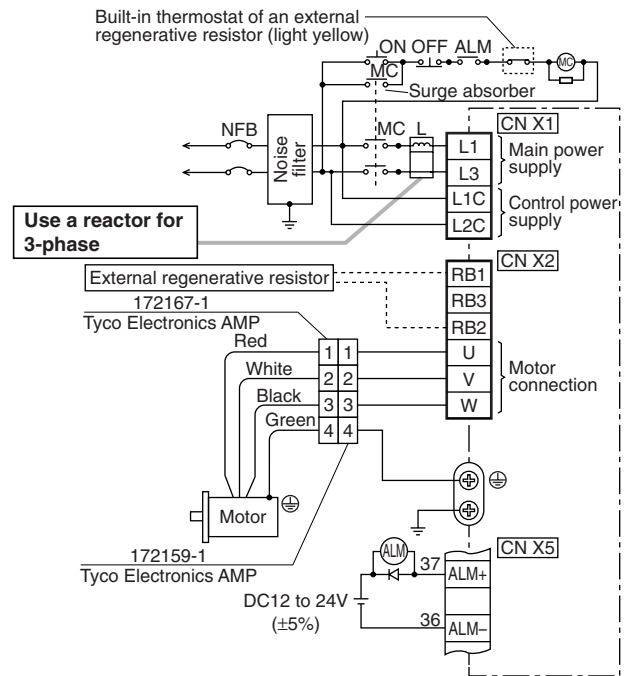

● Frame C, D

• In Case of Single Phase, 200V

<Remarks>

When you use single phase, connect the main power between L1 and L3 terminals.

Use a reactor for 3-phase

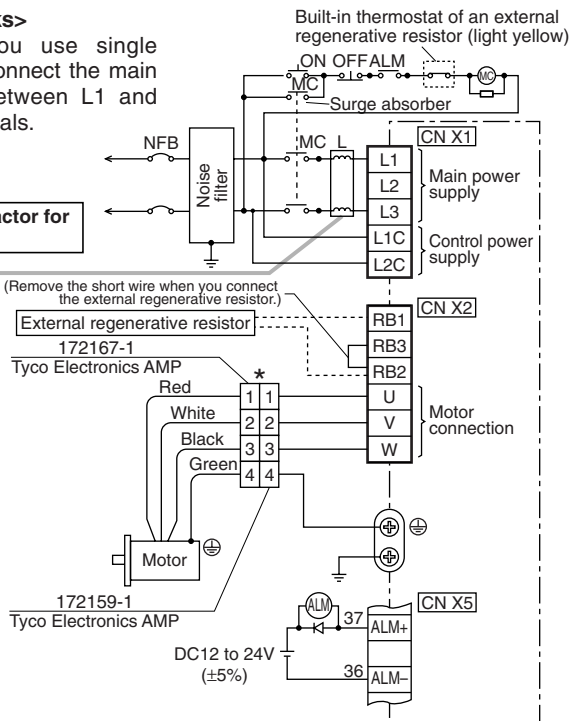

• In Case of 3-Phase, 200V

<Remarks>

When you use single phase, connect the main power between L1 and L3 terminals.

(Remove the short wire when you connect the external regenerative resistor.)

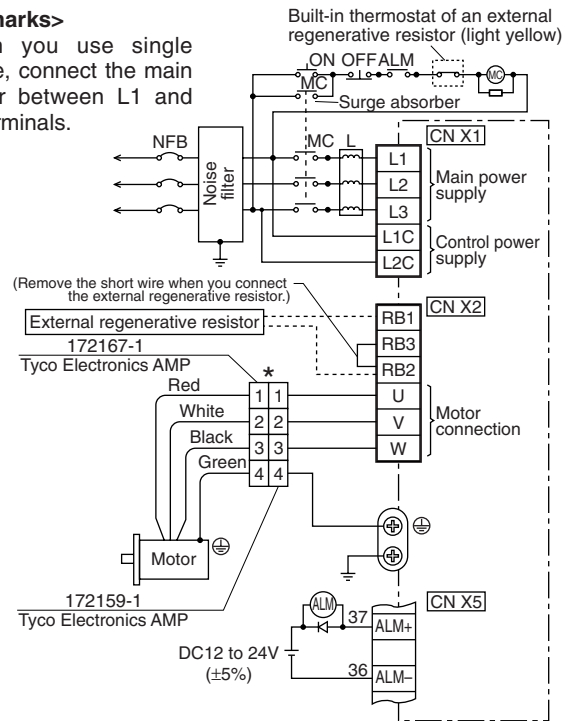

* When you use motor model of MSMA, MDMA, MFMA, MHMA and MGMA, use the connections as the right table shows..

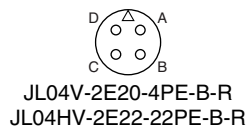

PIN No.	Application
A	U-phase
B	V-phase
C	W-phase
D	Ground

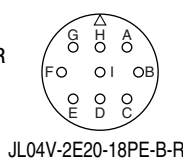

PIN No.	Application
G	Brake
H	Brake
A	NC
F	U-phase
I	V-phase
B	W-phase
E	Ground
D	Ground
C	NC

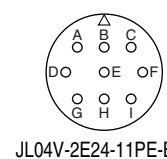

PIN No.	Application
A	Brake
B	Brake
C	NC
D	U-phase
E	V-phase
F	W-phase
G	Ground
H	Ground
I	NC

[Motor portion]

Connector :

by Japan Aviation Electronics Ind.

<Remark>

Do not connect anything to NC.

● Frame E, F

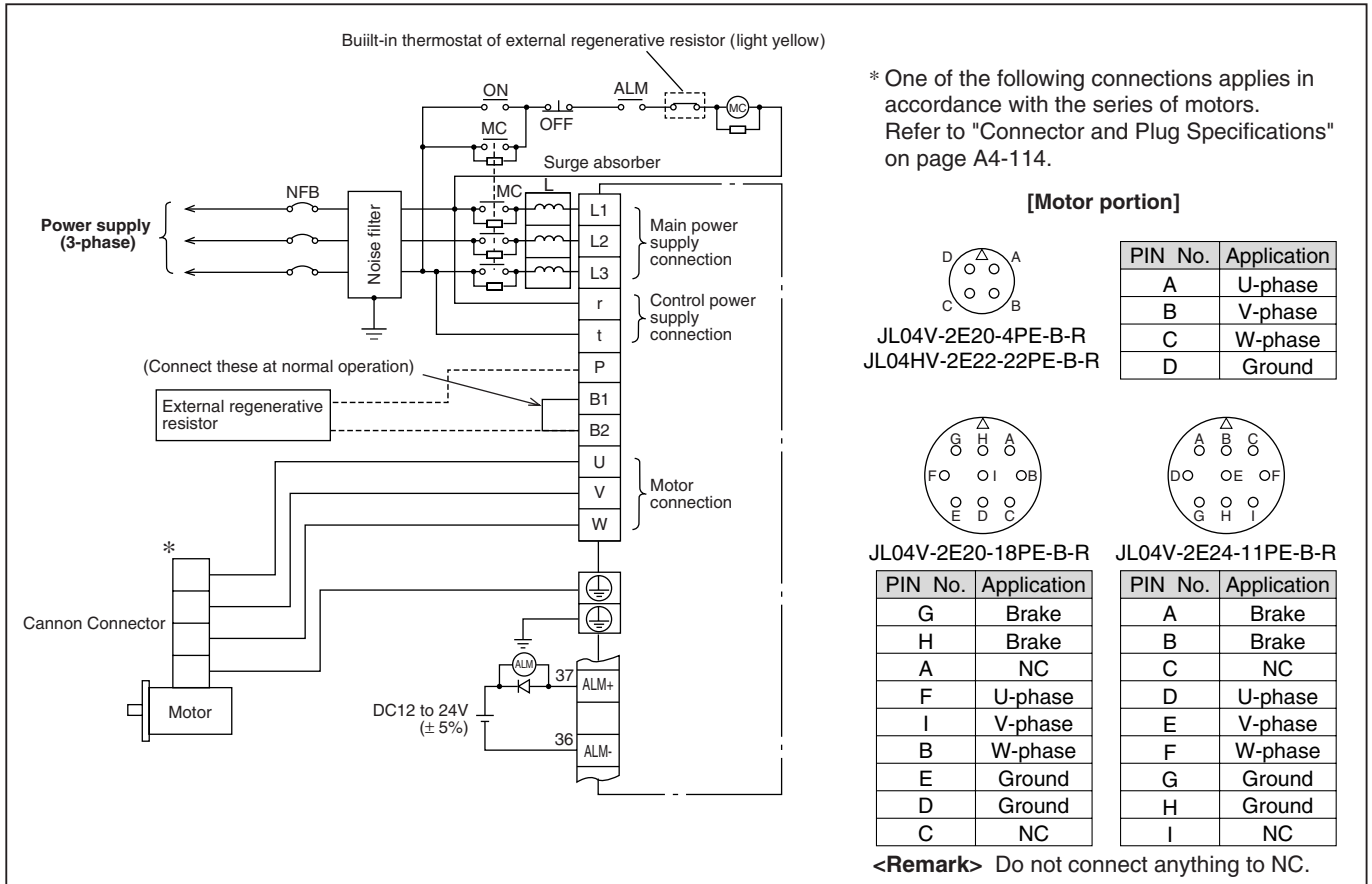

● Frame G

