

Options

Cable part No. designation

Encoder cable

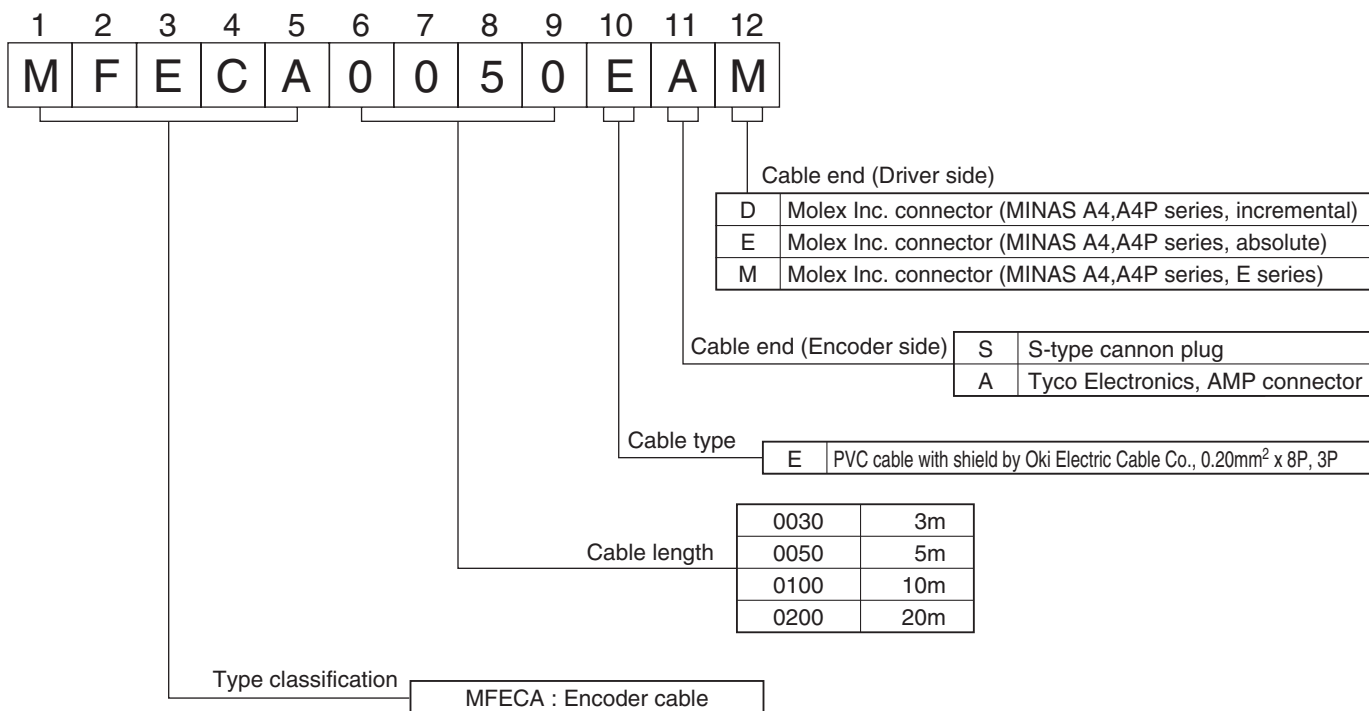

Motor cable, Brake cable

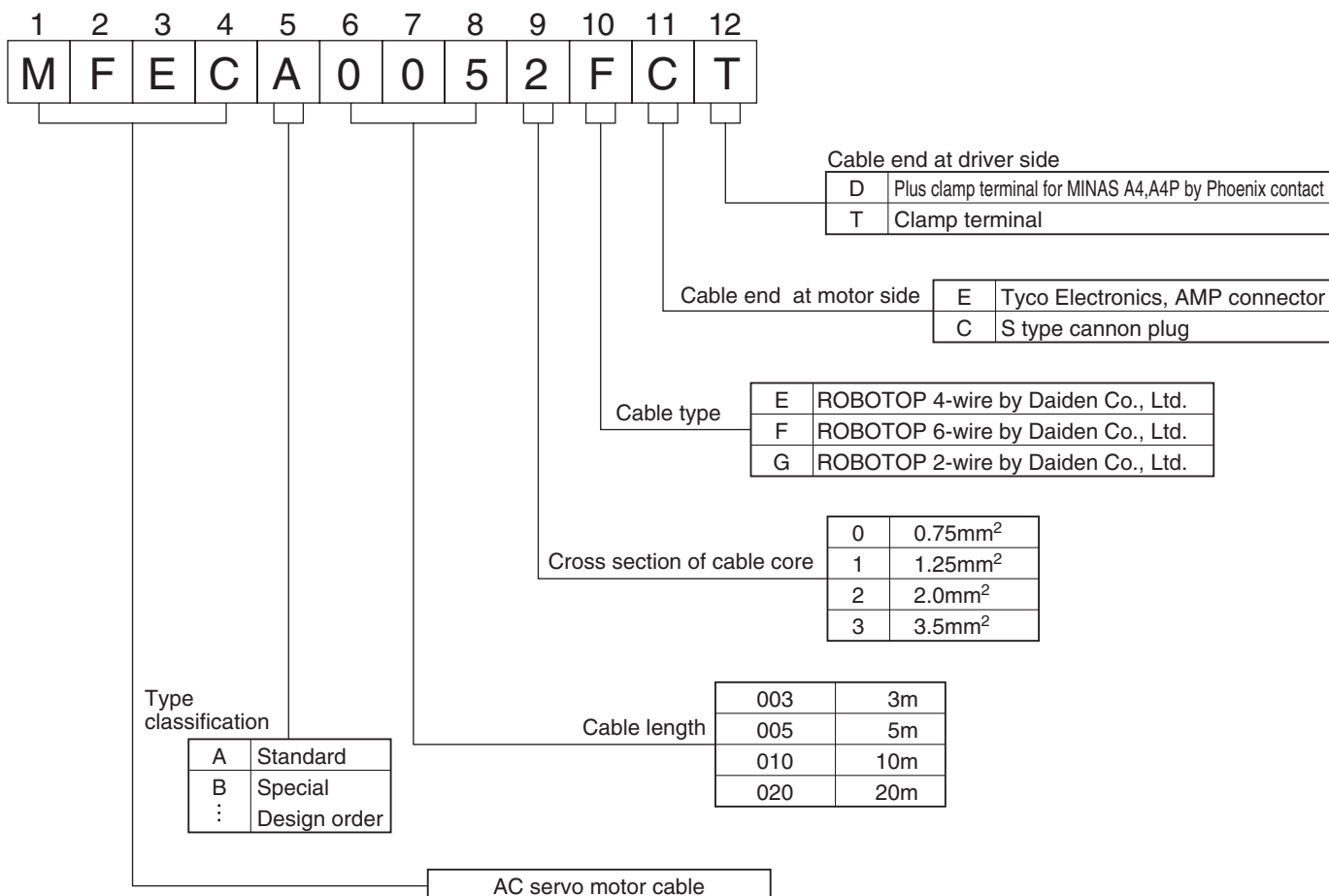

• Pin configuration for encoder connector

MSMA
MDMA
MFMA
MHMA
MGMA

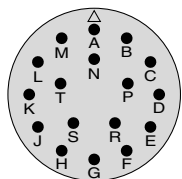

N/MS3102A20-29P

• Specifications of 2500P/r incremental encoder

PIN No.	Content	PIN No.	Content
A	NC	K	PS
B	NC	L	PS
C	NC	M	NC
D	NC	N	NC
E	NC	P	NC
F	NC	R	NC
G	E0V	S	NC
H	E5V	T	NC
J	Frame GND		

MSMA
MDMA
MFMA
MHMA
MGMA

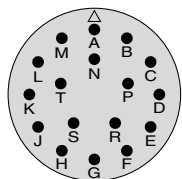

N/MS3102A20-29P

• Specifications of 17bit absolute/incremental encoder

PIN No.	Content	PIN No.	Content
A	NC	K	PS
B	NC	L	PS
C	NC	M	NC
D	NC	N	NC
E	NC	P	NC
F	NC	R	NC
G	E0V	S	BAT-*
H	E5V	T	BAT+*
J	Frame GND		

*Connection to Pin-S and T are not required when used in incremental.

• Pin configuration for motor/brake connector (with brake)

MSMA 1kW, 1.5kW, 2kW
MDMA 1kW, 1.5kW, 2kW
MFMA 400W, 1.5kW
MHMA 500W, 1kW, 1.5kW
MGMA 900W

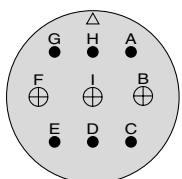

JL04V-2E20-18PE-B-R
(by Japan Aviation Electronics or equivalent)

PIN No.	Content
G	Brake
H	Brake
A	NC
F	U-phase
I	V-phase
B	W-phase
E	Ground
D	Ground
C	NC

MSMA 3kW, 4kW, 5kW
MDMA 3kW, 4kW, 5kW
MFMA 2.5kW, 4.5kW
MHMA 2kW, 3kW, 4kW, 5kW
MGMA 2kW, 3kW, 4.5kW

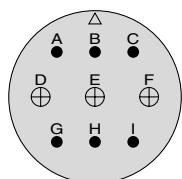

JL04V-2E24-11PE-B-R
(by Japan Aviation Electronics or equivalent)

PIN No.	Content
A	Brake
B	Brake
C	NC
D	U-phase
E	V-phase
F	W-phase
G	Ground
H	Ground
I	NC

MDMA 7.5kW
MGMA 6kW
MHMA 7.5kW

Motor Cable

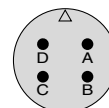

JL04V-2E32-17PE-B-R
(by Japan Aviation Electronics or equivalent)

PIN No.	Content
A	U-phase
B	V-phase
C	W-phase
D	Ground

Brake Cable

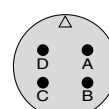

N/MS3102A 14S-2P
(by Japan Aviation Electronics or equivalent)

PIN No.	Content
A	Brake
B	Brake
C	NC
D	NC

• Pin configuration for motor/brake connector (without brake)

MSMA 1kW, 1.5kW, 2kW
MDMA 1kW, 1.5kW, 2kW
MHMA 500W, 1kW, 1.5kW
MGMA 900W

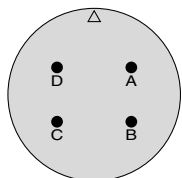

JL04V-2E20-4PE-B-R
(by Japan Aviation Electronics or equivalent)

PIN No.	Content
A	U-phase
B	V-phase
C	W-phase
D	Ground

MSMA 3kW, 4kW, 5kW
MDMA 3kW, 4kW, 5kW
MHMA 2kW, 3kW, 4kW, 5kW
MGMA 2kW, 3kW, 4.5kW

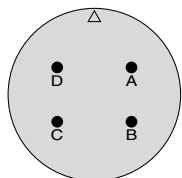

JL04V-2E22-22PE-B-R
(by Japan Aviation Electronics or equivalent)

PIN No.	Content
A	U-phase
B	V-phase
C	W-phase
D	Ground

MDMA 7.5kW
MGMA 6kW
MHMA 7.5kW

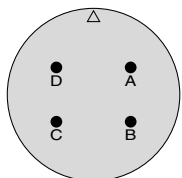

JL04V-2E32-17PE-B-R
(by Japan Aviation Electronics or equivalent)

PIN No.	Content
A	U-phase
B	V-phase
C	W-phase
D	Ground

MFMA 400W, 1.5kW

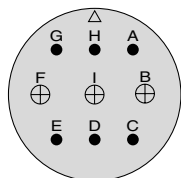

JL04V-2E20-18PE-B-R
(by Japan Aviation Electronics or equivalent)

PIN No.	Content
G	NC
H	NC
A	NC
F	U-phase
I	V-phase
B	W-phase
E	Ground
D	Ground
C	NC

MFMA 2.5kW, 4.5kW

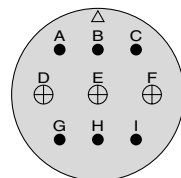

JL04V-2E24-11PE-B-R
(by Japan Aviation Electronics or equivalent)

PIN No.	Content
A	NC
B	NC
C	NC
D	U-phase
E	V-phase
F	W-phase
G	Ground
H	Ground
I	NC

Do not connect anything to NC pins.

Options

Encoder cable

[unit: mm]

MFECA0**0EAE

MSMD50W - 750W, MQMA100W - 400W, MAMA100W - 750W
17-bit absolute encoder, with battery holder

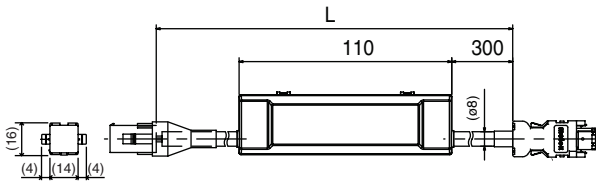

Title	Part No. (Manufacturer's)	Manufacturer
Connector	55100-0600	Molex Inc.
	or 55100-0670	
Connector	172161-1	Tyco Electronics, AMP
Connector pin	170365-1	
Cable	0.20mm ² x 4P	Oki Electric Cable Co.

L(m)	Part No.
3	MFECA0030EAE
5	MFECA0050EAE
10	MFECA0100EAE
20	MFECA0200EAE

Note) Battery for absolute encoder (DV0P2990) is an option.

MFECA0**0ESE

MSMA, MDMA, MHMA, MGMA, MFMA
17-bit absolute encoder, with battery holder

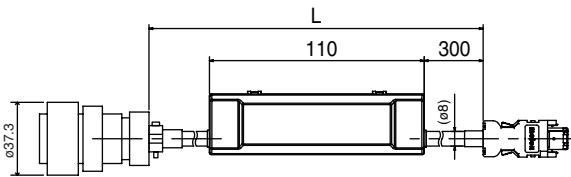

Title	Part No. (Manufacturer's)	Manufacturer
Connector	55100-0600	Molex Inc.
	or 55100-0670	
Straight plug	N/MS3106B20-29S	Japan Aviation
Cable clamp	N/MS3057-12A	Electronics Industry Ltd.
Cable	0.20mm ² x 4P	Oki Electric Cable Co.

L(m)	Part No.
3	MFECA0030ESE
5	MFECA0050ESE
10	MFECA0100ESE
20	MFECA0200ESE

Note) Battery for absolute encoder (DV0P2990) is an option.

MFECA0**0EAD

MSMD50W - 750W, MQMA100W - 400W, MAMA100W - 750W
17-bit incremental encoder, without battery holder

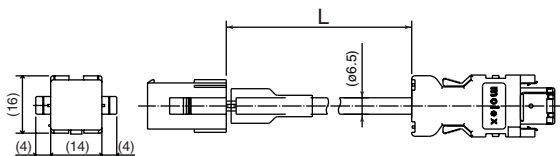

Title	Part No. (Manufacturer's)	Manufacturer
Connector	55100-0600	Molex Inc.
	or 55100-0670	
Connector	172161-1	Tyco Electronics, AMP
Connector pin	170365-1	
Cable	0.20mm ² x 3P	Oki Electric Cable Co.

L(m)	Part No.
3	MFECA0030EAD
5	MFECA0050EAD
10	MFECA0100EAD
20	MFECA0200EAD

MFECA0**0ESD

MSMA, MDMA, MHMA, MGMA, MFMA
17-bit incremental/2500P/r encoder, without battery holder

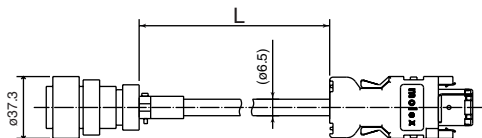

Title	Part No. (Manufacturer's)	Manufacturer
Connector	55100-0600	Molex Inc.
	or 55100-0670	
Straight plug	N/MS3106B20-29S	Japan Aviation
Cable clamp	N/MS3057-12A	Electronics Industry Ltd.
Cable	0.20mm ² x 3P	Oki Electric Cable Co.

L(m)	Part No.
3	MFECA0030ESD
5	MFECA0050ESD
10	MFECA0100ESD
20	MFECA0200ESD

MFECA0**0EAM

MSMD50W - 750W, MQMA100W - 400W, MAMA100W - 750W
2500P/r encoder, without battery holder

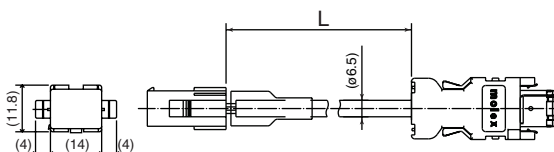

Title	Part No. (Manufacturer's)	Manufacturer
Connector	55100-0600	Molex Inc.
	or 55100-0670	
Connector	172160-1	Tyco Electronics, AMP
Connector pin	170365-1	
Cable	0.20mm ² x 3P	Oki Electric Cable Co.

L(m)	Part No.
3	MFECA0030EAM
5	MFECA0050EAM
10	MFECA0100EAM
20	MFECA0200EAM

Motor cable (ROBO TOP® 105°C,600V, DP)

[unit: mm]

ROBO TOP® is a trade mark of Daiden Co., Ltd.

MFMCA00EED**

MSMD50W - 750W, MQMA100W - 400W, MAMA100W - 750W

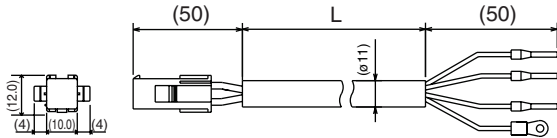

Title	Part No. (Manufacturer's)	Manufacturer
Connector	172159-1	Tyco Electronics, AMP
Connector pin	170366-1	
Rod terminal	AI0.75-8GY	Phoenix
Nylon insulated roundterminal	N1.25-M4	J.S.T. Mfg. Co., Ltd.
Cable	ROBO-TOP 600V 0.75mm ²	Daiden Co., Ltd.

L (m)	Part No.
3	MFMCA0030EED
5	MFMCA0050EED
10	MFMCA0100EED
20	MFMCA0200EED

MFMCDO2ECD**

MSMA1.0kW - 1.5kW, MDMA1.0kW - 1.5kW
MHMA500W - 1.5kW, MGMA900W

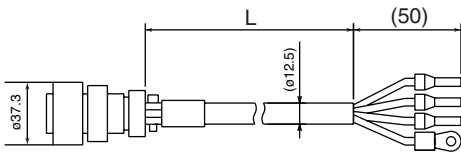

Title	Part No. (Manufacturer's)	Manufacturer
Straight plug	JL04V-6A20-4SE-EB-R	Japan Aviation
Cable clamp	JL04-2022CK(14)-R	Electronics Industry Ltd.
Rod terminal	AI2.5-8BU	Phoenix
Nylon insulated roundterminal	N2-M4	J.S.T. Mfg. Co., Ltd.
Cable	ROBO-TOP 600V 2.0mm ²	Daiden Co., Ltd.

L (m)	Part No.
3	MFMCD0032ECD
5	MFMCD0052ECD
10	MFMCD0102ECD
20	MFMCD0202ECD

MFMCDO2ECT**

MSMA2.0kW, MDMA2.0kW

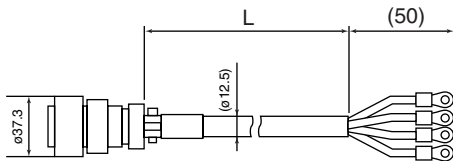

Title	Part No. (Manufacturer's)	Manufacturer
Straight plug	JL04V-6A20-4SE-EB-R	Japan Aviation
Cable clamp	JL04-2022CK(14)-R	Electronics Industry Ltd.
Nylon insulated roundterminal	N2-5	J.S.T. Mfg. Co., Ltd.
Cable	ROBO-TOP 600V 2.0mm ²	Daiden Co., Ltd.

L (m)	Part No.
3	MFMCD0032ECT
5	MFMCD0052ECT
10	MFMCD0102ECT
20	MFMCD0202ECT

MFMCAO3ECT**

MSMA3.0kW - 5.0kW, MDMA3.0kW - 5.0kW
MHMA2.0kW - 5.0kW, MGMA2.0kW - 4.5kW

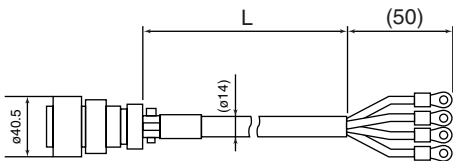

Title	Part No. (Manufacturer's)	Manufacturer
Straight plug	JL04V-6A20-22SE-EB-R	Japan Aviation
Cable clamp	JL04-2022CK(14)-R	Electronics Industry Ltd.
Nylon insulated roundterminal	N5.5-5	J.S.T. Mfg. Co., Ltd.
Cable	ROBO-TOP 600V 3.5mm ²	Daiden Co., Ltd.

L (m)	Part No.
3	MFMCA0033ECT
5	MFMCA0053ECT
10	MFMCA0103ECT
20	MFMCA0203ECT

MFMCAO**

MFMA400W - 1.5kW

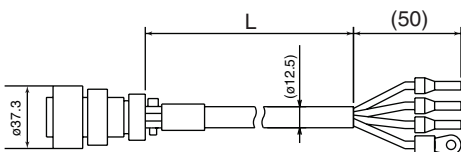

Title	Part No. (Manufacturer's)	Manufacturer
Straight plug	JL04V-6A20-18SE-EB-R	Japan Aviation
Cable clamp	JL04-2022CK(14)-R	Electronics Industry Ltd.
Rod terminal	AI2.5-8BU	Phoenix
Nylon insulated roundterminal	N2-M4	J.S.T. Mfg. Co., Ltd.
Cable	ROBO-TOP 600V 2.0mm ²	Daiden Co., Ltd.

L (m)	Part No.
3	MFMCA0032ECD
5	MFMCA0052ECD
10	MFMCA0102ECD
20	MFMCA0202ECD

MFMCDO3ECT**

MFMA2.5kW - 4.5kW

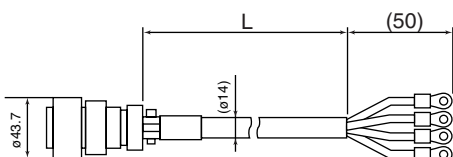

Title	Part No. (Manufacturer's)	Manufacturer
Straight plug	JL04V-6A24-11SE-EB-R	Japan Aviation
Cable clamp	JL04-2428CK(17)-R	Electronics Industry Ltd.
Nylon insulated roundterminal	N5.5-5	J.S.T. Mfg. Co., Ltd.
Cable	ROBO-TOP 600V 3.5mm ²	Daiden Co., Ltd.

L (m)	Part No.
3	MFMCD0033ECT
5	MFMCD0053ECT
10	MFMCD0103ECT
20	MFMCD0203ECT

Options

Brake cable (ROBO-TOP® 105°C 600V · DP)

[unit: mm]

MFMCB00GET**

MSMD 50W - 750W
MQMA 100W - 400W
MAMA 100W - 750W

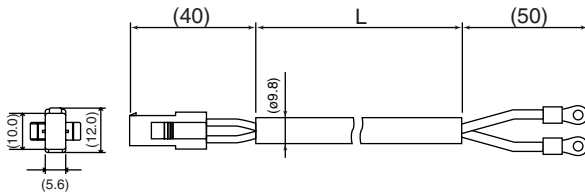

Title	Part No. (Manufacturer's)	Manufacturer	L(m)	Part No.
Connector	172157-1	Japan Aviation	3	MFMCB0030GET
Connector pin	170366-1,170362-1	Electronics Industry Ltd.	5	MFMCB0050GET
Nylon insulated roundterminal	N1.25-M4	J.S.T. Mfg. Co., Ltd.	10	MFMCB0100GET
Cable	ROBO-TOP 600V 0.75mm ²	Daiden Co., Ltd.	20	MFMCB0200GET

Motor cable (with brake) (ROBO-TOP® 105°C 600V · DP)

[unit: mm]

ROBO TOP® is a trade mark of Daiden Co., Ltd.

MFMCAO2FCD**

MSMA 1.0kW - 1.5kW, MDMA 1.0kW - 1.5kW
MHMA 500W - 1.5kW, MFMA 400W - 1.5kW
MGMA 900W

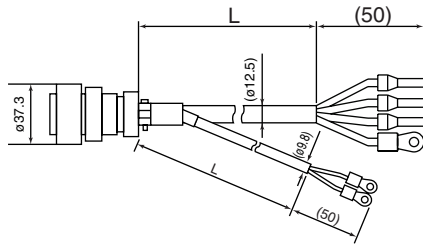

Title	Part No. (Manufacturer's)	Manufacturer	L(m)	Part No.
Straight plug	JL04V-6A20-18SE-EB-R	Japan Aviation	3	MFMCA0032FCD
Cable clamp	JL04-2022CK(14)-R	Electronics Industry Ltd.	5	MFMCA0052FCD
Rod terminal	AI2.5-8BU	Phoenix	10	MFMCA0102FCD
Nylon insulated roundterminal	N2-M4	J.S.T. Mfg. Co., Ltd.	20	MFMCA0202FCD
	N1.25-M4			
Cable	ROBO-TOP 600V 2.0mm ² or ROBO-TOP 600V 0.75mm ²	Daiden Co., Ltd.		

MFMCAO2FCT**

MSMA 2.0kW, MDMA 2.0kW

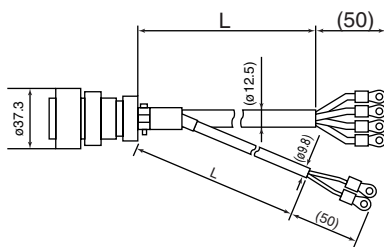

Title	Part No. (Manufacturer's)	Manufacturer	L(m)	Part No.
Straight plug	JL04V-6A20-18SE-EB-R	Japan Aviation	3	MFMCA0032FCT
Cable clamp	JL04-2022CK(14)-R	Electronics Industry Ltd.	5	MFMCA0052FCT
Nylon insulated roundterminal	N2-5	J.S.T. Mfg. Co., Ltd.	10	MFMCA0102FCT
	N1.25-M4		20	MFMCA0202FCT
Cable	ROBO-TOP 600V 2.0mm ² or ROBO-TOP 600V 0.75mm ²	Daiden Co., Ltd.		

MFMCA03FCT**

MSMA 3.0kW - 5.0kW, MDMA 3.0kW - 5.0kW
MHMA 2.0kW - 5.0kW, MFMA 2.5kW - 4.5kW
MGMA 2.0kW - 4.5kW

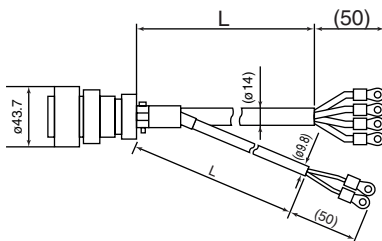

Title	Part No. (Manufacturer's)	Manufacturer	L(m)	Part No.
Straight plug	JL04V-6A24-11SE-EB-R	Japan Aviation	3	MFMCA0033FCT
Cable clamp	JL04-2428CK(17)-R	Electronics Industry Ltd.	5	MFMCA0053FCT
Nylon insulated roundterminal	N5.5-5	J.S.T. Mfg. Co., Ltd.	10	MFMCA0103FCT
	N1.25-M4		20	MFMCA0203FCT
Cable	ROBO-TOP 600V 3.5mm ² or ROBO-TOP 600V 0.75mm ²	Daiden Co., Ltd.		

Connector kit for external peripheral equipments

● MINAS A4, A4F

1) Par No. **DV0P4350**

2) Components

Title	Part No.	Quantity	Manufacturer	Note
Connector	54306-5011 or 54306-5019 (lead-free)	1	Molex Inc.	For CN X5 (50-pins)
Connector cover	54331-0501	1		

3) Pin disposition (50 pins) (viewed from the soldering side)

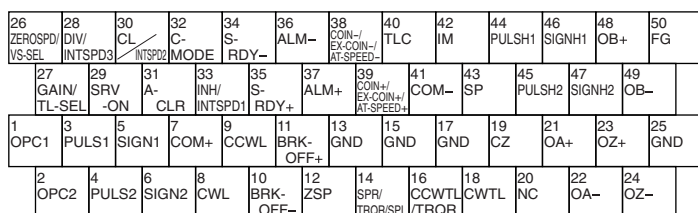

<Cautions>

- 1) Check the stamped pin-No. on the connector body while making a wiring.
- 2) For the function of each signal title or its symbol, refer to the wiring example of the connector CN I/F.
- 3) Check the stamped pin-No. on the connector body while making a wiring.

● MINAS A4P

1) Par No. **DV0P4500**

2) Components

Title	Part No.	Quantity	Manufacturer	Note
Connector	54306-3611 or 54306-3619 (lead-free)	1	Molex Inc.	For CN X5 (36-pins)
Connector cover	54331-0361	1		

3) Pin disposition (36 pins) (viewed from the soldering side)

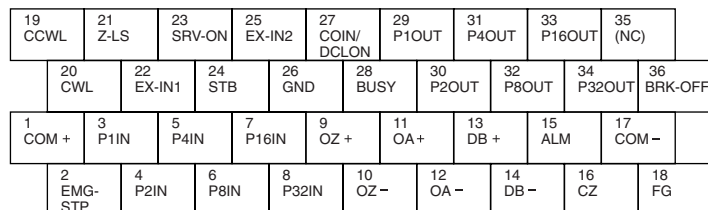

<Cautions>

- 1) Check the stamped pin-No. on the connector body while making a wiring.
- 2) For the function of each signal title or its symbol, refer to the wiring example of the connector CN I/F.
- 3) Check the stamped pin-No. on the connector body while making a wiring.

Options

Interface cable

[unit: mm]

● MINAS A4, A4F

Cable of 2m is connected.

1) Part No. **DV0P4360**

2) Dimensions

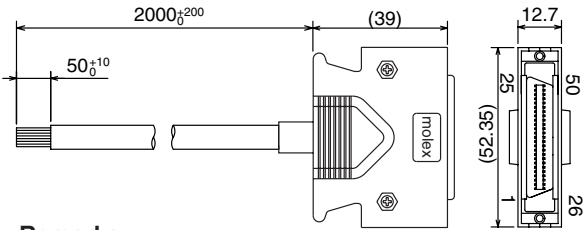

<Remarks>

Color designation of the cable
e.g.) Pin-1 Cable color : Orange
(Red1) : One red dot on the cable

3) Table for wiring

PIN No.	color	PIN No.	color	PIN No.	color	PIN No.	color	PIN No.	color
1	Orange (Red1)	11	Orange (Black2)	21	Orange (Red3)	31	Orange (Red4)	41	Orange (Red5)
2	Orange (Black1)	12	Yellow (Black1)	22	Orange (Black3)	32	Orange (Black4)	42	Orange (Black5)
3	Gray (Red1)	13	Gray (Red2)	23	Gray (Red3)	33	Gray (Red4)	43	Gray (Red5)
4	Gray (Black1)	14	Gray (Black2)	24	Gray (Black3)	34	White (Red4)	44	White (Red5)
5	White (Red1)	15	White (Red2)	25	White (Red3)	35	White (Black4)	45	White (Black5)
6	White (Black1)	16	Yellow (Red2)	26	White (Black3)	36	Yellow (Red4)	46	Yellow (Red5)
7	Yellow (Red1)	17	Yel(Blk2)/Pink(Blk2)	27	Yellow (Red3)	37	Yellow (Black4)	47	Yellow (Black5)
8	Pink (Red1)	18	Pink (Red2)	28	Yellow (Black3)	38	Pink (Red4)	48	Pink (Red5)
9	Pink (Black1)	19	White (Black2)	29	Pink (Red3)	39	Pink (Black4)	49	Pink (Black5)
10	Orange (Red2)	20	—	30	Pink (Black3)	40	Gray (Black4)	50	Gray (Black5)

● MINAS A4P

1) Part No. **DV0P4510**

2) Dimensions

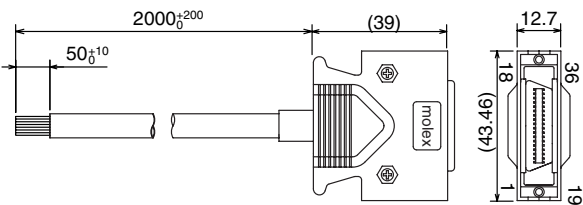

<Remarks>

Color designation of the cable
e.g.) Pin-1 Cable color : Orange
(Red1) : One red dot on the cable

3) Table for wiring

PIN No.	color	PIN No.	color	PIN No.	color
1	Orange(Red1)	13	Gray(Red2)	25	White(Red3)
2	Orange(Black1)	14	Gray(Black2)	26	White(Black3)
3	Gray(Red1)	15	White(Red2)	27	Yellow(Red3)
4	White(Red1)	16	White(Black2)	28	Yellow(Black3)
5	White(Black1)	17	Yellow(Red2)	29	Pink(Red3)
6	Gray(Black1)	18	Yellow(Black2)	30	Pink(Black3)
7	Yellow(Red1)	19	Pink(Red2)	31	Orange(Red4)
8	Yellow(Black1)	20	Pink(Black2)	32	Orange(Black4)
9	Pink(Red1)	21	Orange(Red3)	33	Gray(Red4)
10	Pink(Black1)	22	Orange(Black3)	34	Gray(Black4)
11	Orange(Red2)	23	Gray(Red3)	35	White(Red4)
12	Orange(Black2)	24	Gray(Black3)	36	White(Black4)

Communication cable (for connection with PC)

[unit: mm]

1) Part No. **DV0P1960**

2) Dimensions

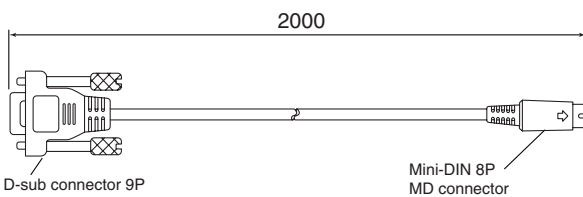

Communication cable (for RS485) < This cable cannot be used for the A4P series >

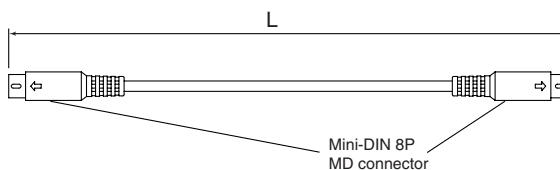

Part No.	L[mm]
DV0P1970	200
DV0P1971	500
DV0P1972	1000

Connector kit for motor and encoder

<Notification>

There may be cases where parts equivalent to those indicated by the part Nos. shown follow are used as components such as connectors, connector covers, straight plugs and cable clamps.

- **Applicable motor models : MSMD 50W to 750W**
MQMA 100W to 400W
MAMA 100W to 750W [17-bit absolute] For brake, purchase our optional brake cable.

1) Part No. **DV0P4290**

2) Components

Title	Part No.	Number	Manufacturer	Note
Connector	55100-0600 or 55100-0670 (lead-free)	1	Molex Inc.	For CN X6 (6-pins)
Connector	172161-1	1	Tyco Electronics AMP	For junction cable to encoder (9-pins)
Connector pin	170365-1	9		
Connector	172159-1	1	Tyco Electronics AMP	For junction cable to motor (4-pins)
Connector pin	170366-1	4		

3) Pin configuration of connector, CN X6

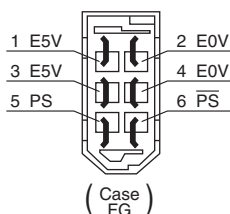

4) Pin configuration of junction cable for encoder

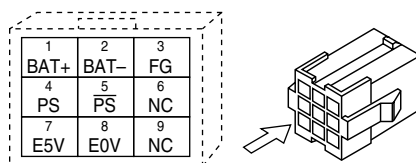

5) Pin configuration of junction cable for motor power

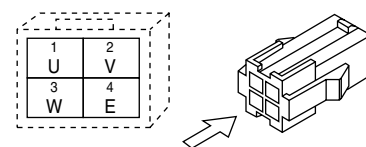

*When you connect the battery for absolute encoder, refer to A4-154, "When you make your own cable for 17-bit absolute encoder"

- **Applicable motor models : MSMD 50W to 750W**
MQMA 100W to 400W
MAMA 100W to 750W [2500P/r incremental encoder] For brake, purchase our optional brake cable.

1) Part No. **DV0P4380**

2) Components

Title	Part No.	Number	Manufacturer	Note
Connector	55100-0600 or 55100-0670 (lead-free)	1	Molex Inc.	For CN X6 (6-pins)
Connector	172160-1	1	Tyco Electronics AMP	For junction cable to encoder (6-pins)
Connector pin	170365-1	6		
Connector	172159-1	1	Tyco Electronics AMP	For junction cable to encoder (4-pins)
Connector pin	170366-1	4		

3) Pin configuration of connector, CN X6

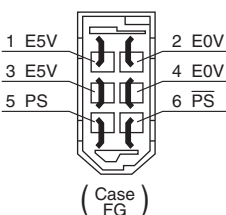

4) Pin configuration of junction cable for encoder

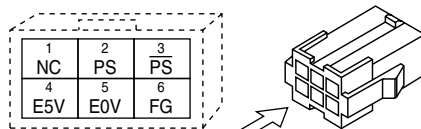

5) Pin configuration of junction cable for motor power

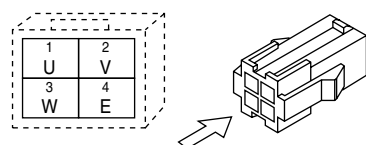

- **For DV0P2490, DV0P4380, recommended manual crimp tool**
 (to be prepared by customer)

Title	Part No.	Manufacturer
For junction cable to encoder	755330 - 1	Tyco Electronics AMP
For junction cable to motor	755331 - 1	

Options

Pin configuration of connector CN X6 plug

- Shown in the figure at right is the pin configuration as seen from the soldering side of the connector. Also check the pin No. inscribed on the case main body and take care to carry out wiring properly.
- Be sure to connect to the case (FG) the shield of the shielded wire to be used.
- For wiring and connecting, refer to pages A4-19, 45 and 71.

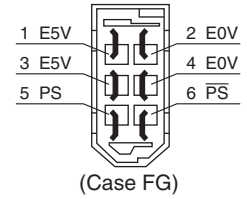

- Applicable motor models : MSMA 1.0kW to 2.0kW
MDMA 1.0kW to 2.0kW
MHMA 500W to 1.5kW
MGMA 900W
- [17-bit absolute incremental encoder, 2500P/r incremental encoder] Without brake

1) Part No. **DV0P4310**

2) Components

Title	Part No.	Number	Manufacturer	Note
Connector	55100-0600 or 55100-0670	1	Molex Inc.	For CN X6 (6-pins)
Straight plug	N/MS3106B20-29S	1	Japan Aviation Electronics Industry Ltd.	For junction cable to encoder
Cable clamp	N/MS3057-12A	1		
Straight plug	N/MS3106B20-4S	1	Japan Aviation Electronics Industry Ltd.	For junction cable to motor power
Cable clamp	N/MS3057-12A	1		

- Applicable motor models : MSMA 3.0kW to 5.0kW
MDMA 3.0kW to 5.0kW
MHMA 2.0kW to 5.0kW
MGMA 2.0kW to 4.5kW
- [17-bit absolute incremental encoder, 2500P/r incremental encoder] Without brake

1) Part No. **DV0P4320**

2) Components

Title	Part No.	Number	Manufacturer	Note
Connector	55100-0600 or 55100-0670	1	Molex Inc.	For CN X6 (6-pins)
Straight plug	N/MS3106B-20-29S	1	Japan Aviation Electronics Industry Ltd.	For junction cable to encoder
Cable clamp	N/MS3057-12A	1		
Straight plug	N/MS3106B22-22S	1	Japan Aviation Electronics Industry Ltd.	For junction cable to motor power
Cable clamp	N/MS3057-12A	1		

- Applicable motor models : MSMA 1.0kW to 2.0kW
MDMA 1.0kW to 2.0kW
MHMA 0.5kW to 1.5kW
MGMA 900W
- [17-bit absolute incremental encoder, 2500P/r incremental encoder] With brake

MFMA 0.4kW to 1.5kW [17-bit absolute incremental encoder, 2500P/r incremental encoder] Without brake
With brake

1) Part No. **DV0P4330**

2) Components

Title	Part No.	Number	Manufacturer	Note
Connector	55100-0600 or 55100-0670	1	Molex Inc.	For CN X6 (6-pins)
Straight plug	N/MS3106B20-29S	1	Japan Aviation Electronics Industry Ltd.	For junction cable to encoder
Cable clamp	N/MS3057-12A	1		
Straight plug	N/MS3106B20-18S	1	Japan Aviation Electronics Industry Ltd.	For junction cable to motor power
Cable clamp	N/MS3057-12A	1		

- Applicable motor models : MSMA 3.0kW to 5.0kW
MDMA 3.0kW to 5.0kW [17-bit absolute incremental encoder, 2500P/r incremental encoder] With brake
MHMA 2.0kW to 5.0kW
MGMA 2.0kW to 4.5kW
- MFMA 2.5kW to 4.5kW [17-bit absolute incremental encoder, 2500P/r incremental encoder] Without brake
With brake

1) Part No. **DV0P4340**

2) Components

Title	Part No.	Number	Manufacturer	Note
Connector	55100-0600 or 55100-0670	1	Molex Inc.	For CN X6 (6-pins)
Straight plug	N/MS3106B20-29S	1	Japan Aviation Electronics Industry Ltd.	For junction cable to encoder
Cable clamp	N/MS3057-12A	1		
Straight plug	N/MS3106B24-11S	1	Japan Aviation Electronics Industry Ltd.	For junction cable to motor power
Cable clamp	N/MS3057-16A	1		

- Applicable motor models : MDMA 7.5kW
MGMA 6.0kW [17-bit absolute incremental encoder, 2500P/r incremental encoder] Without brake
MHMA 7.5kW

1) Part No. **DV0PM20005**

2) Components

Title	Part No.	Number	Manufacturer	Note
Connector	55100-0600 or 55100-0670 (lead-free)	1	Molex Inc.	For CN X6 (6-pins)
Straight plug	N/MS3106B20-29S	1	Japan Aviation Electronics Industry Ltd.	For junction cable to encoder
Cable clamp	N/MS3057-12A	1		
Straight plug	N/MS3106B32-17S	1	Japan Aviation Electronics Industry Ltd.	For junction cable to motor power
Cable clamp	N/MS3057-20A	1		

- Applicable motor models : MDMA 7.5kW
MGMA 6.0kW [17-bit absolute incremental encoder, 2500P/r incremental encoder] With brake
MHMA 7.5kW

1) Part No. **DV0PM20006**

2) Components

Title	Part No.	Number	Manufacturer	Note
Connector	55100-0600 or 55100-0670 (lead-free)	1	Molex Inc.	For CN X6 (6-pins)
Straight plug	N/MS3106B20-29S	1	Japan Aviation Electronics Industry Ltd.	For junction cable to encoder
Cable clamp	N/MS3057-12A	1		
Straight plug	N/MS3106B32-17S	1	Japan Aviation Electronics Industry Ltd.	For junction cable to motor power
Cable clamp	N/MS3057-20A	1		
Straight plug	N/MS3106B14S-2S	1	Japan Aviation Electronics Industry Ltd.	For junction cable to brake cable
Cable clamp	N/MS3057-6A	1		

1) Part No. **DV0PM20010**

2) Components

Title	Part No.	Number	Manufacturer	Note
Connector	55100-0600 or 55100-0670 (lead-free)	1	Molex Inc.	For CN X6 or CN X7 (6-pins)

Options

Setup support software "PANATERM"

- 1) Part No. **DV0P4460** (Japanese/English version)
- 2) Supply media : CD-ROM

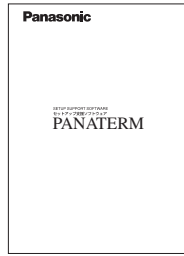

<Caution>

For information on the software and operating environment, refer to p.F2 of this document or [PANATERM] instruction manual.

Mounting bracket

Frame symbol of applicable driver	part No.	Mounting screw	Dimensions [unit: mm]	
			Upper side	Bottom side
Frame A	DV0P4271	M4 x L6 Pan head 4pcs	<p>Upper side view of Frame A mounting bracket. Dimensions: 17mm height, 9.5mm hole offset, 11 ± 0.2mm hole spacing, 15mm total width, 10mm hole offset, 7mm hole diameter, 21mm total width. Features 2-M4 Pan head screws and a 2.6mm wide L-shaped bracket.</p>	<p>Bottom side view of Frame A mounting bracket. Dimensions: 17mm height, 9.5mm hole offset, 11 ± 0.2mm hole spacing, 15mm total width, 10mm hole offset, 7mm hole diameter, 21mm total width. Features 2-M4 Pan head screws, a 5.2mm wide L-shaped bracket, and a 2.6mm wide L-shaped bracket. Includes a R2.6 fillet.</p>
Frame B	DV0P4272	M4 x L6 Pan head 4pcs	<p>Upper side view of Frame B mounting bracket. Dimensions: 17mm height, 9.5mm hole offset, 18 ± 0.2mm hole spacing, 15mm total width, 10mm hole offset, 7mm hole diameter, 28mm total width. Features 2-M4 Pan head screws and a 2.6mm wide L-shaped bracket.</p>	<p>Bottom side view of Frame B mounting bracket. Dimensions: 17mm height, 9.5mm hole offset, 18 ± 0.2mm hole spacing, 15mm total width, 10mm hole offset, 7mm hole diameter, 28mm total width. Features 2-M4 Pan head screws, a 5.2mm wide L-shaped bracket, and a 2.6mm wide L-shaped bracket. Includes a R2.6 fillet.</p>
Frame C	DV0P4273	M4 x L6 Pan head 4pcs	<p>Upper side view of Frame C mounting bracket. Dimensions: 17mm height, 9.5mm hole offset, 30 ± 0.2mm hole spacing, 15mm total width, 10mm hole offset, 7mm hole diameter, 40mm total width. Features 2-M4 Pan head screws and a 2.6mm wide L-shaped bracket.</p>	<p>Bottom side view of Frame C mounting bracket. Dimensions: 17mm height, 9.5mm hole offset, 30 ± 0.2mm hole spacing, 15mm total width, 10mm hole offset, 7mm hole diameter, 40mm total width. Features 2-M4 Pan head screws, a 5.2mm wide L-shaped bracket, and a 2.6mm wide L-shaped bracket.</p>
Frame D	DV0P4274	M4 x L6 Pan head 4pcs	<p>Upper side view of Frame D mounting bracket. Dimensions: 17mm height, 9.5mm hole offset, 19mm hole offset, 36 ± 0.2mm hole spacing, 15mm total width, 10mm hole offset, 7mm hole diameter, 60mm total width. Features 2-M4 Pan head screws and a 2.6mm wide L-shaped bracket.</p>	<p>Bottom side view of Frame D mounting bracket. Dimensions: 17mm height, 9.5mm hole offset, 5mm hole offset, 36 ± 0.2mm hole spacing, 15mm total width, 10mm hole offset, 7mm hole diameter, 60mm total width. Features 2-M4 Pan head screws, two 5.2mm wide L-shaped brackets, and a 2.6mm wide L-shaped bracket.</p>

<Caution> For Frame E, F you can make a front end and back end mounting by changing the mounting direction of L-shape bracket (attachment).

Console

[unit: mm]

1) Part No. **DV0P4420** Caution) An existing console(DV0P3690) cannot be used for the A4P series.

2) Dimensions

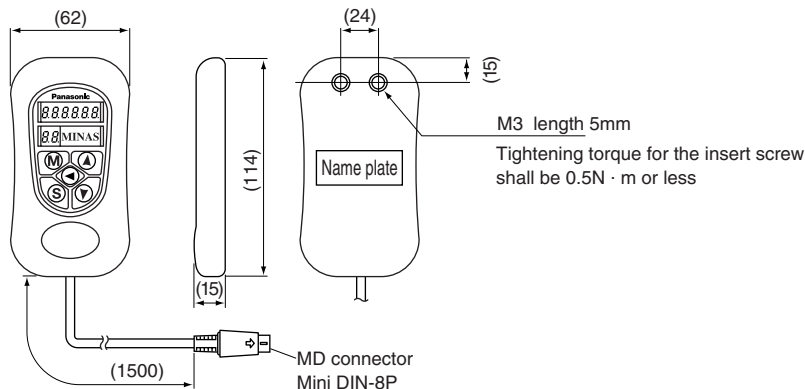

Reactor

Fig.1

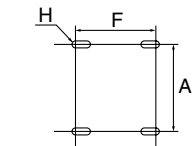
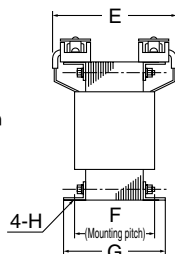
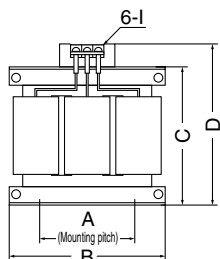
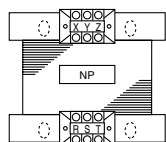

F: Center-to-center distance on outer circular arc

Fig.2

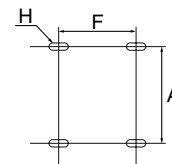
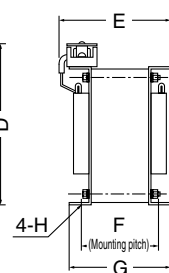
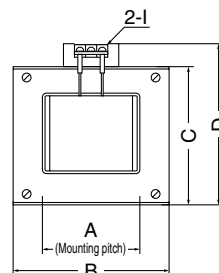

F: Center-to-center distance on slotted hole

[unit: mm]

	Part No.	A	B	C	D	E (Max)	F	G	H	I	Inductance (mH)	Rated current (A)
Fig. 1	DV0P220	65±1	125±1	(93)	136Max	155	70 + 3/-0	85±2	4-7ø x 12	M4	6.81	3
	DV0P221	60±1	150±1	(113)	155Max	130	60 + 3/-0	75±2	4-7ø x 12	M4	4.02	5
	DV0P222	60±1	150±1	(113)	155Max	140	70 + 3/-0	85±2	4-7ø x 12	M4	2	8
	DV0P223	60±1	150±1	(113)	155Max	150	79 + 3/-0	95±2	4-7ø x 12	M4	1.39	11
	DV0P224	60±1	150±1	(113)	160Max	155	84 + 3/-0	100±2	4-7ø x 12	M4	0.848	16
	DV0P225	60±1	150±1	(113)	160Max	170	100 + 3/-0	115±2	4-7ø x 12	M5	0.557	25
Fig. 2	DV0P227	55±0.7	80±1	66.5±1	110Max	90	41±2	55±2	4-5ø x 10	M4	4.02	5
	DV0P228	55±0.7	80±1	66.5±1	110Max	95	46±2	60±2	4-5ø x 10	M4	2	8

Harmonic restraint on general-purpose inverter and servo driver

On September, 1994, Guidelines for harmonic restraint on heavy consumers who receive power through high voltage system or extra high voltage system and Guidelines for harmonic restraint on household electrical appliances and general-purpose articles established by the Agency for Natural Resources and Energy of the Ministry of Economy, Trade and Industry (the ex-Ministry of International Trade and Industry). According to those guidelines, the Japan Electrical Manufacturers Association (JEMA) have prepared technical documents (procedure to execute harmonic restraint: JEM-TR 198, JEM-TR 199 and JEM-TR 201) and have been requesting the users to understand the restraint and to cooperate with us. On January, 2004, it has been decided to exclude the general-purpose inverter and servo driver from the Guidelines for harmonic restraint on household electrical appliances and general-purpose articles". After that, the Guidelines for harmonic restraint on household electrical appliances and general-purpose articles was abolished on September 6, 2004.

We are pleased to inform you that the procedure to execute the harmonic restraint on general-purpose inverter and servo driver will be modified as follows.

1. All types of the general-purpose inverters and servo drivers used by specific users are under the control of the Guidelines for harmonic restraint on heavy consumers who receive power through high voltage system or extra high voltage system". The users who are required to apply the guidelines must calculate the equivalent capacity and harmonic current according to the guidelines and must take appropriate countermeasures if the harmonic current exceeds a limit value specified in a contract demand. (Refer to JEM-TR 210 and JEM-TR 225.)
2. The Guidelines for harmonic restraint on household electrical appliances and general-purpose articles was abolished on September 6, 2004. However, based on conventional guidelines, JEMA applies the technical documents JEM-TR 226 and JEM-TR 227 to any users who do not fit into the Guidelines for harmonic restraint on heavy consumers who receive power through high voltage system or extra high voltage system from a perspective on enlightenment on general harmonic restraint. The purpose of these guidelines is the execution of harmonic restraint at every device by a user as usual to the utmost extent.

<Remarks> When using a reactor, be sure to install one reactor to one servo driver.

Options

External regenerative resistor

Part No.	Manufacturer's part No.	Specifications					Activation temperature of built-in thermostat
		Resistance	Retard power (reference)*				
			Free air	with fan[W]			
1m/s	2m/s	3m/s					
DV0P4280	RF70M	50 Ω	10W	25	35	45	140 ±5°C B-contact Open/Close capacity (resistance load) 4A 125VAC 10000 times 2.5A 250VAC 10000 times
DV0P4281	RF70M	100 Ω	10W	25	35	45	
DV0P4282	RF180B	25 Ω	17W	50	60	75	
DV0P4283	RF180B	50 Ω	17W	50	60	75	
DV0P4284	RF240	30 Ω	40W	100	120	150	
DV0P4285	RH450F	20 Ω	52W	130	160	200	

*Power with which the driver can be used without activating the built-in thermostat.
Manufacturer : Iwaki Musen Kenkyusho

[unit: mm]

DV0P4280, DV0P4281

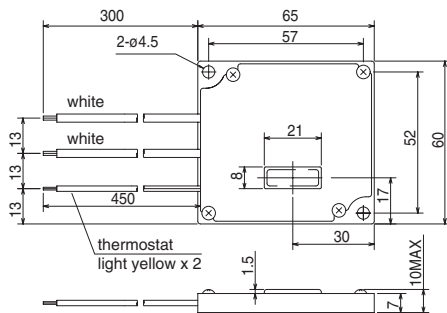

DV0P4282, DV0P4283

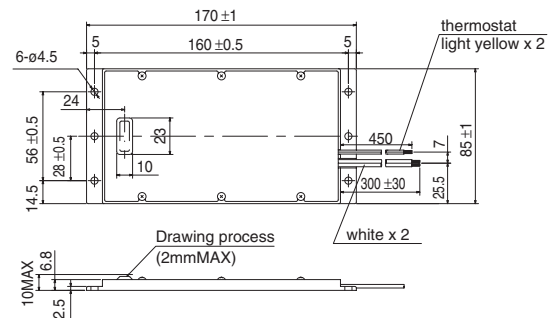

DV0P4284

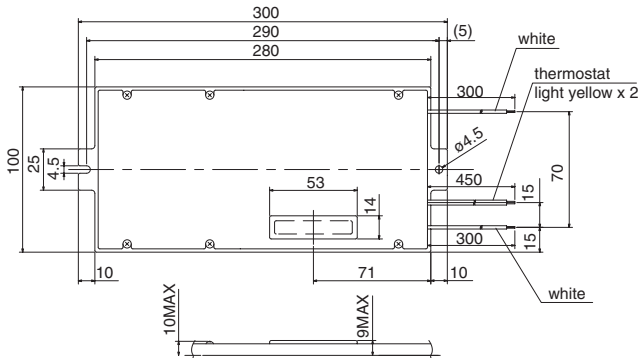

DV0P4285

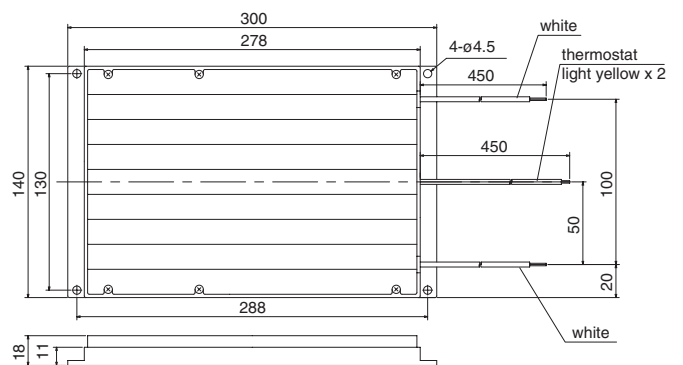

<Remarks>

Thermal fuse and thermostat are installed for safety. Compose the circuit so that the power will be turned off when the thermostat is activated. The thermal fuse may blow due to heat dissipating condition, working temperature, supply voltage or load fluctuation.

Make it sure that the surface temperature of the resistor may not exceed 100°C at the worst running conditions with the machine, which brings large regeneration (such case as high supply voltage, load inertia is large or deceleration time is short) Install a fan for a forced cooling if necessary.

<Caution>

Regenerative resistor gets very hot.

Take preventive measures for fire and burns.
Avoid the installation near inflammable objects,
and easily accessible place by hand.

Battery for absolute encoder (Frame A to G)

[unit: mm]

- 1) Part No. **DV0P2990**
- 2) Lithium battery, 3.6V 2000mAh

<Caution>

This battery is categorized as hazardous substance, and you may be required to present an application of hazardous substance when you transport by air (both passenger and cargo airlines).

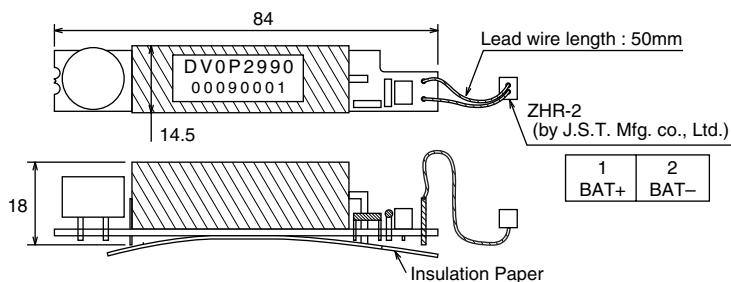

Battery holder for absolute encoder

[unit: mm]

- 1) Part No. **DV0P4430**

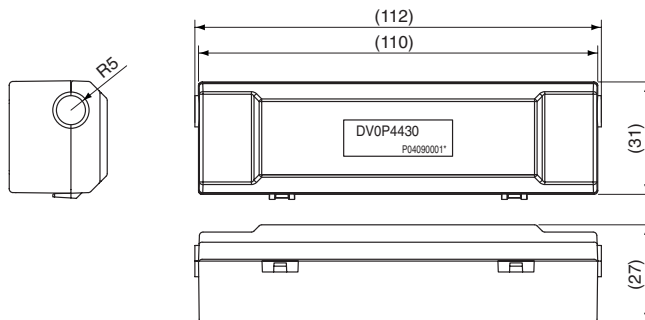

When you make your own cable for 17-bit absolute encoder

When you make your own cable for 17-bit absolute encoder, connect the optional battery for absolute encoder, DV0P2990 as per the wiring diagram below. Connector of the battery for absolute encoder to be provided by customer.

<Cautions>

Install and fix the battery securely. If the installation and fixing of the battery is not appropriate, it may cause the wire breakdown or damage of the battery.
Refer to the instruction manual of the battery for handling of the battery.

• where to install the battery

- (1) indoors, where the products are not subjected to rain or direct sun beam
- (2) where the products are not subjected to corrosive atmospheres such as hydrogen sulfide, sulfurous acid, chlorine, ammonia, chloric gas, acid, alkaline, salt and so on, and free from splash of inflammable gas, grinding oil, oil mist, iron powder or chips and etc.
- (3) well-ventilated and humid and dust free place
- (4) vibration-free place

Wiring Diagram

