

# Conformity to CE and UL

## Compliance to EC and EMC Directives

### EC Directives

The EC Directives apply to all such electronic products as those having specific functions and have been exported to EU and directly sold to general consumers. Those products are required to conform to the EU unified standards and to furnish the CE marking on the products.

MINAS AC Servos conforms to the EC Directives for Low Voltage Equipment so that the machine incorporating our servos has an easy access to the conformity to relevant EC Directives for the machine.

### EMC Directives

MINAS Servo System conforms to relevant standards under EMC Directives setting up certain model (condition) with certain locating distance and wiring of the servo motor and the driver. And actual working condition often differs from this model condition especially in wiring and grounding. Therefore, in order for the machine to conform to the EMC Directives, especially for noise emission and noise terminal voltage, it is necessary to examine the machine incorporating our servos.

### Conformed Standards

Subject	Conformed Standard		
Motor	IEC60034-1	IEC60034-5 UL1004 CSA22.2 No.100	Conforms to Low-Voltage Directives
	EN50178	UL508C CSA22.2 No.14	
Motor and driver	EN55011	Radio Disturbance Characteristics of Industrial, Scientific and Medical (ISM) Radio-Frequency Equipment	Standards referenced by EMC Directives
	EN61000-6-2	Immunity for Industrial Environments	
	IEC61000-4-2	Electrostatic Discharge Immunity Test	
	IEC61000-4-3	Radio Frequency Electromagnetic Field Immunity Test	
	IEC61000-4-4	Electric High-Speed Transition Phenomenon/Burst Immunity Test	
	IEC61000-4-5	Lightening Surge Immunity Test	
	IEC61000-4-6	High Frequency Conduction Immunity Test	
	IEC61000-4-11	Instantaneous Outage Immunity Test	

IEC : International Electrotechnical Commission  
 EN : Europaischen Normen  
 EMC : Electromagnetic Compatibility  
 UL : Underwriters Laboratories  
 CSA : Canadian Standards Association

Pursuant to at the directive 2004/108/EC,article 9(2)

Panasonic Testing Centre  
 Panasonic Service Europe,  
 a division of Panasonic Marketing Europe GmbH  
 Winsbergring 15,22525 Hamburg,F.R.Germany

## Composition of peripheral equipment

### <Precautions in using options>

Use options correctly after reading operation manuals of the options to better understand the precautions.

Take care not to apply excessive stress to each optional part.

### Installation environment

Use the MINAS driver in environment of Pollution Degree

1 or 2 prescribed in IEC-60664-1

(e.g. Install the driver in control panel with IP54 protection structure.)

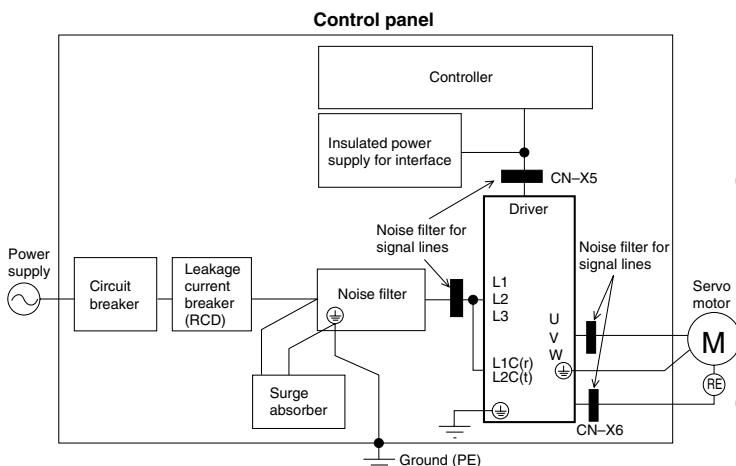

### Power supply

100V system : Single phase 100V	+10%	-15%	-115V	+10%	-15%	50/60Hz
(Frame A to C)						
200V system : Single 200V	+10%	-15%	-240V	+10%	-15%	50/60Hz
(Frame A to B)						
200V system : Single/3- phase 200V	+10%	-15%	-240V	+10%	-15%	50/60Hz
(Frame C to D)						
200V system : 3- phase 200V	+10%	-15%	-230V	+10%	-15%	50/60Hz
(Frame E to G)						

(1) This product is designed to be used under Overvoltage Category (Installation Category) II of EN50178 :1997. Install a surge absorber which conforms to EN61643-11 : 2002 and other relevant standards at the power entry when you want to use this product under Overvoltage Category (Installation Category) III.

(2) For a interface power supply, use an insulated one with 12 to 24 VDC which conforms to CE Marking or EN Standards.

**Circuit breaker**

Connect a circuit breaker which conforms to IEC standards and is UL recognized (UL Listed, ) marked), between the power supply and the noise filter.

**Noise filter**

When you install one noise filter in the power supply for multi-axes application, consult with the manufacture of the filter.

Option part No.	Part No.	Manufacturer
DV0P4170	SUP-EK5-ER-6	Okaya Electric Industries Co.
DV0P4180	3SUP-HQ10-ER-6	
DV0P4220	3SUP-HU30-ER-6	
DV0P3410	3SUP-HL50-ER-6B	

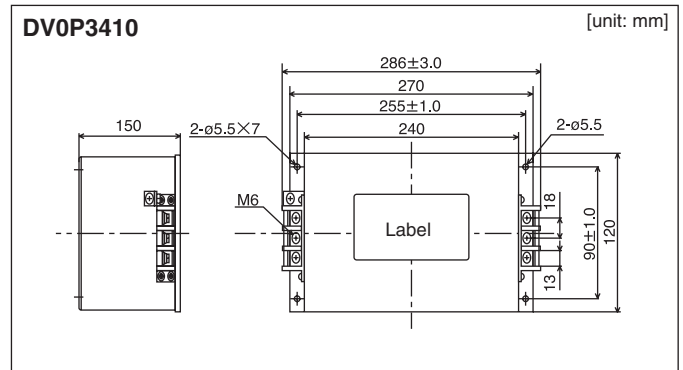
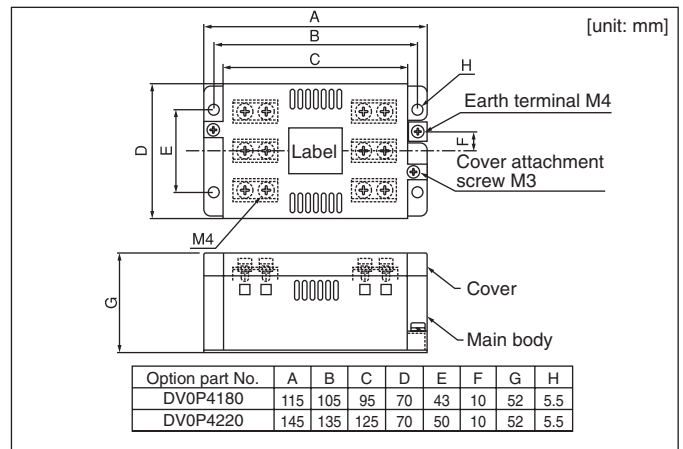
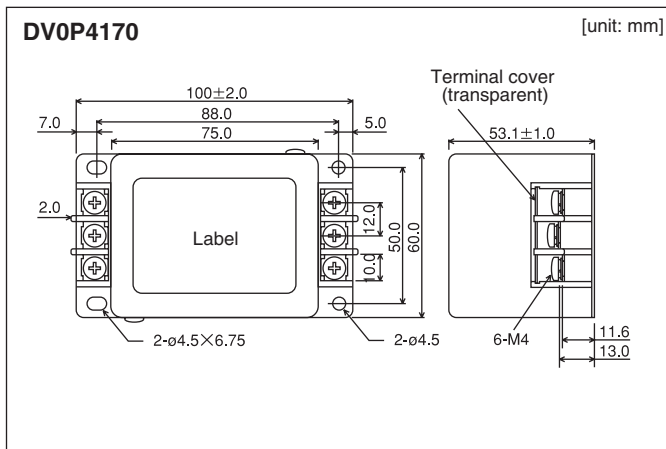

**Surge absorber**

Install a surge absorber at primary side of the noise filter.

Option part No.	Driver voltage spec	Part No.	Manufacturer
DV0P1450	3-phase, 200V	R · A · V-781BXZ-4	Okaya Electric

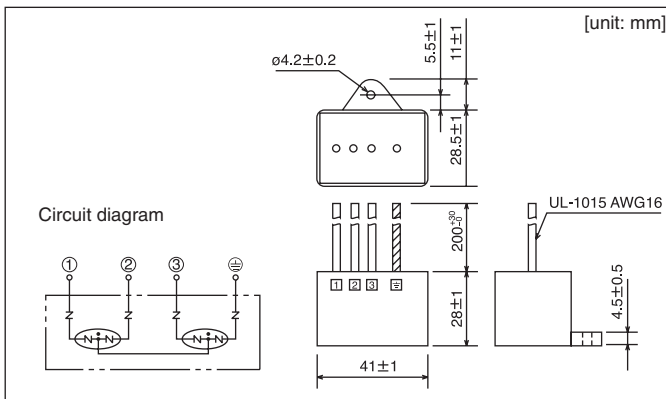

Option part No.	Driver voltage spec	Part No.	Manufacturer
DV0P4190	Single phase, 100V, 200V	R · A · V-781BWZ-4	Okaya Electric

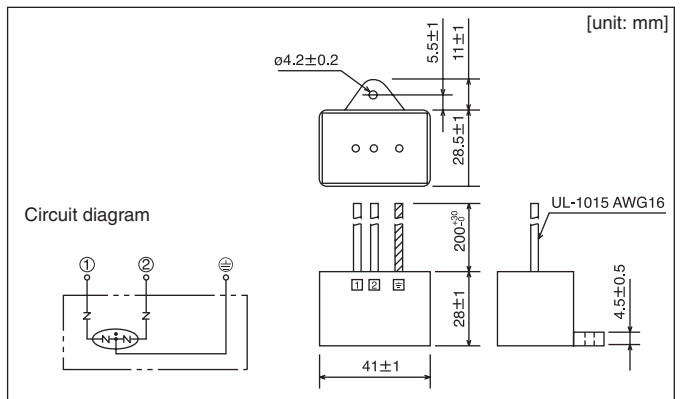

**<Remarks>**

Remove this surge absorber when you perform dielectric test on the machine, or surge absorber might be damaged.

# Conformity to CE and UL

## Noise filter for signal lines

Install noise filters for signal lines to all cables (Power line, motor cable, encoder cable, interface cable)

Option part No.	Part No.	Qty.	Manufacturer
DV0P1460	ZCAT3035-1330	4	TDK Corp.

### <Caution>

Fix the signal line noise filter in place to eliminate excessive stress to the cables.

(Refer to page A4-137 [Composition of peripheral equipment])

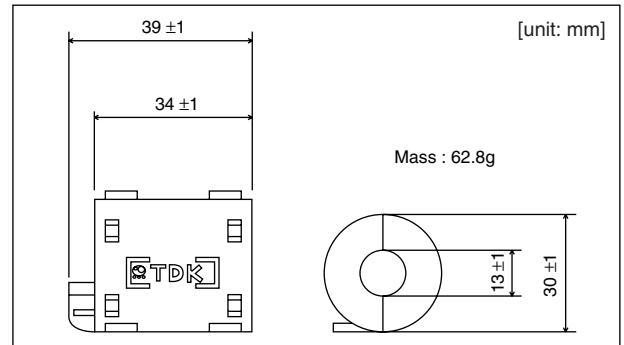

## Ground-fault breaker

Install a B-type ground-fault breaker (RCD) at primary side of the power supply of the driver.

## Grounding

- (1) Connect the protective earth terminal of the driver (⊕) and protective earth terminal of the control panel (PE) without fail to prevent electrical shocks.
- (2) Do not co-clamp to the protective earth terminals (⊕). Two protective earth terminals are provided.

## Conformity to UL Standards

Observe the following conditions of (1) and (2) to make the system conform to UL508C (File No. E164620).

- (1) Use the driver in an environment of Pollution Degree 2 or 1 prescribed in IEC60664-1. (e.g. Install in the control box with IP54 enclosure.)
- (2) Install a circuit breaker or fuse which are UL recognized (LISTED  marked) between the power supply and the noise filter without fail.

For the rated current of the circuit breaker or fuse, refer to P.A4-12, A4-38, A4-63, "List of recommended peripheral equipments". Use a copper cable with temperature rating of 60°C or higher.

Tightening torque of more than the max. values (M4:1.2N·Em, M5: 2.0N·Em) may break the terminal block.