

THIRD ANGLE PROJECTION

ITEM CODE	CAPACITANCE μF (*)	DIMENSIONS		
		*L	*T	*H
ECQV 1J103JM3	0.01 (103)	7.5	3.2	6.8
" 1J123JM3	0.012 (123)	"	"	"
" 1J153JM3	0.015 (153)	"	"	"
" 1J183JM3	0.018 (183)	"	"	"
" 1J223JM3	0.022 (223)	"	"	"
" 1J273JM3	0.027 (273)	"	"	"
" 1J333JM3	0.033 (333)	"	"	"
" 1J393JM3	0.039 (393)	"	"	"
" 1J473JM3	0.047 (473)	"	"	"
" 1J563JM3	0.056 (563)	"	"	"
" 1J683JM3	0.068 (683)	"	"	"
" 1J823JM3	0.082 (823)	"	"	"
" 1J104JM3	0.1 (104)	"	"	7.0
" 1J124JM3	0.12 (124)	"	3.8	"
" 1J154JM3	0.15 (154)	"	4.1	"
" 1J184JM3	0.18 (184)	10.2	3.5	9.0
" 1J224JM3	0.22 (224)	"	"	"
" 1J274JM3	0.27 (274)	"	"	"
" 1J334JM3	0.33 (334)	"	3.8	"
" 1J394JM3	0.39 (394)	"	4.0	"
" 1J474JM3	0.47 (474)	"	4.5	"
" 1J564JM3	0.56 (564)	"	4.9	"
" 1J684JM3	0.68 (684)	"	5.5	10.0
" 1J824JM3	0.82 (824)	"	6.1	"
" 1J105JM3	1.0 (105)	"	6.9	"

ITEM CODE NUMBER STRUCTURE

ECQV 1J103JM3 (63VDC, 0.01μF, ±5%)

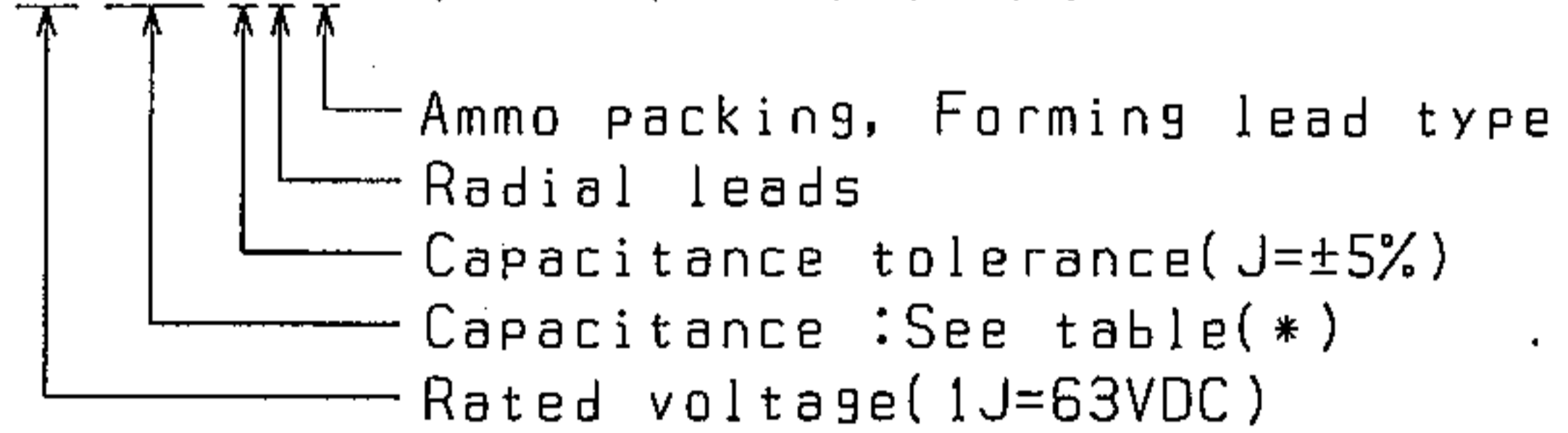

CONSTRUCTION

The capacitor is of non-inductive construction with metallized polyester film and acrylic resin dielectric.

The capacitor is enclosed in epoxy resin and has two leads.

MARKING

Marking comprises capacitance and manufacturer's date code.

PROPERTIES

- Capacitance : See table (*) at 1kHz
- Capacitance tolerance : ±5%(J)
- Rated voltage : 63VDC
- Insulation resistance : I. R ≥ 3,000MΩ when C ≤ 0.33μF
C. R ≥ 1,000MΩ·μF when C > 0.33μF } at 50VDC, 20°C
- Withstand voltage (terminal-terminal) : Rated voltage × 150% for 60s
- ★ Dissipation factor : ≤ 1.0% at 1kHz, 20°C
- Category temperature range : From -40°C to +85°C
(Including temperature rise on unit surface)

DO NOT SCALE DRAWING REVISIONS INDICATED BY Δ ALL DIMENSIONS ARE IN MILLIMETERS

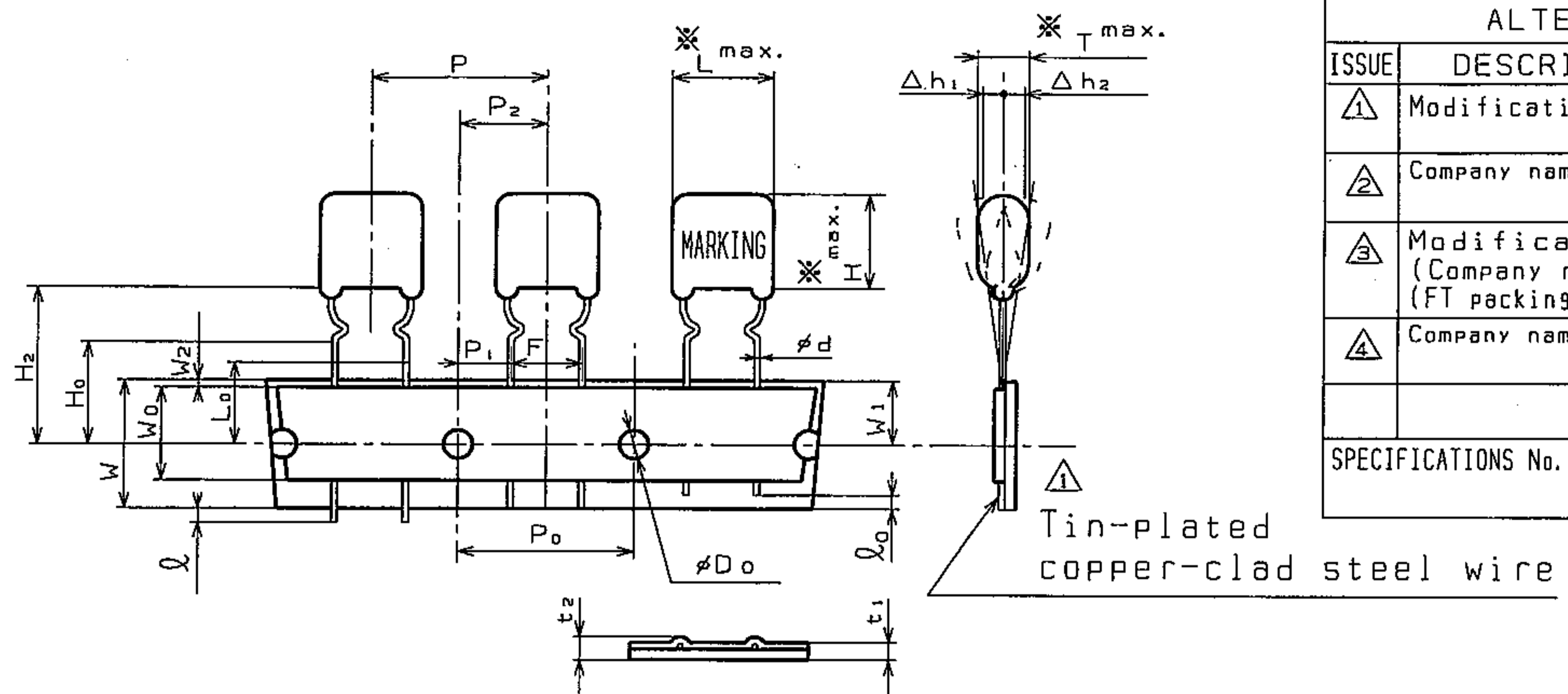

SYMBOL	ITEM	VALUE	TOLERANCE	REMARKS
P	Pitch of component	12.7	± 1.0	Tilt of component and curvature of leads shall be included.
P ₀	Feed hole pitch	12.7	± 0.2	
P ₁	Feed hole center to lead	3.85	± 0.5	
P ₂	Hole center to comp. center	6.35	± 1.3	Tilt of component due to curvature of leads shall be included.
φ d	Lead-wire diameter	0.5	± 0.05	
F	Lead-to-lead distance	5.0	+ 0.8 - 0.2	
Δh _{1,2}	Component alignment	0-2.0	—	Tilt of component due to curvature of leads shall be included.
W	Paper backing width	18.0	± 0.5	
W ₀	Adhesive tape width	9.5	min.	The hold down tape shall not protrude beyond the carrier tape.
W ₁	Hole position	9.0	± 0.5	
W ₂	Hold-down tape position	0-3.0	—	
H ₂	Component height	20.0	± 0.75	
H ₀	Lead wire clinch height	16.0	± 0.5	
L	Lead wire protrusion	0	max.	
L ₀	Lead wire depression	7.0	max.	
φ D ₀	Feed hole diameter	4.0	± 0.2	
t ₁	Total tape thickness	0.7	± 0.2	Total thickness including the hold down tape.
t ₂	Total thickness	1.5	max.	
L ₀	Length of snipped lead	11.0	max.	

ALTERATION		
ISSUE	DESCRIPTION	DATE
△1	Modification	Aug. 1 2002
△2	Company name changed	Oct. 20 2004
△3	Modification (Company name) (FT packing case logo)	Apr. 1 2005
△4	Company name changed	Apr. 1 2006

SPECIFICATIONS No.

Reference

(example)

1 0 3

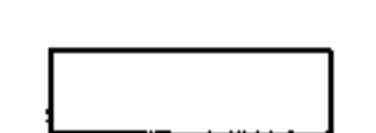

date code

DESIGN	Y. Sasaki
CHECKED	M. Nishikawa
APPROVAL	M. Nagaoke
ESTABLISHMENT	Jan. 31. 2000
TYPE NAME	ECQV 1J...JM3
NAME STACKED METALLIZED FILM CAPACITOR	
DRAWING NAME	PRODUCT DRAWING
DRAWING No.	CV-H-B46B(1/2)

Panasonic Electronic Devices Co.,Ltd.
Capacitor Business Unit.
Panasonic Electronic Devices Matsue Co.,Ltd.

646631.03

THIRD ANGLE PROJECTION

- Note 1. No more than 3 consecutive missing is permitted.
 Note 2. A tape conjunction and a tape discrepancy specify as follows.

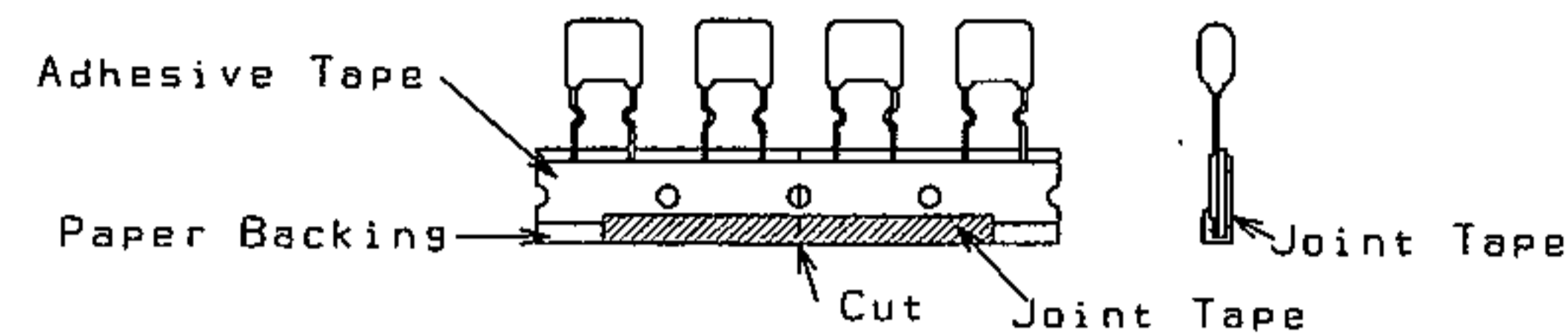

A tape sliding shall not exceed in an allowance of P_0 dimension.
 A joint tape put on the back side of paper backing, and turn up the lower part to the front.

- Note 3. A tape trailer having at least 3 feed holes is required at the end of the tape.
 Note 4. Marking on components may not be the same side.
 Note 5. The tape adhesion is more than $3.92N(400gf)/25mm$.
 Note 6. The lead crimping shape shows as follows.

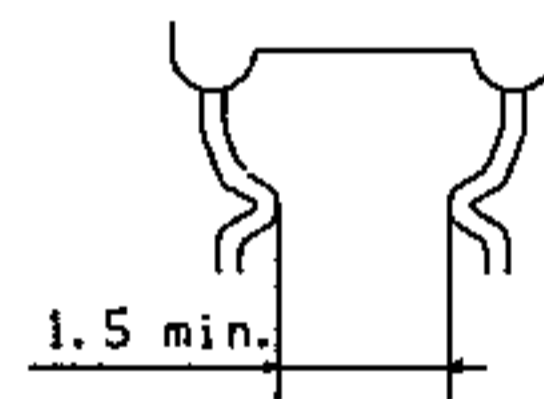

- Note 7.
 1) The P_1 and P_2 dimension shall be measured as shown in the figure after the adhesive tape placing upward.
 (measuring from the center of sprocket hole to the right.)
 2) The P_2 dimension shall be measured between center of a vertical projection plane for tape plane and center of sprocket hole.

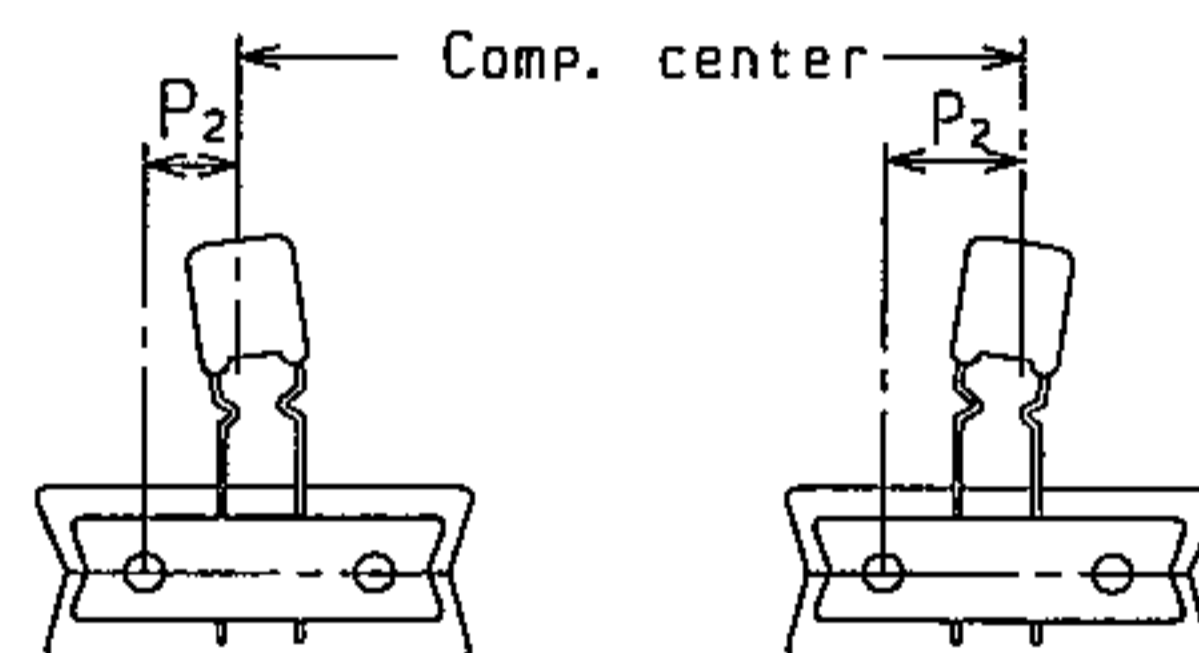

- Note 8. The component is removed from the fold area.
 (Applicable capacitance range (824~105))

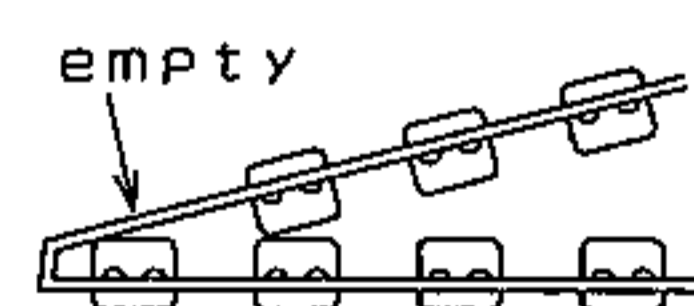

(The number of products is based to one breaking 24 pieces.)

Packing specification
 1. Case size (Ammo pack)

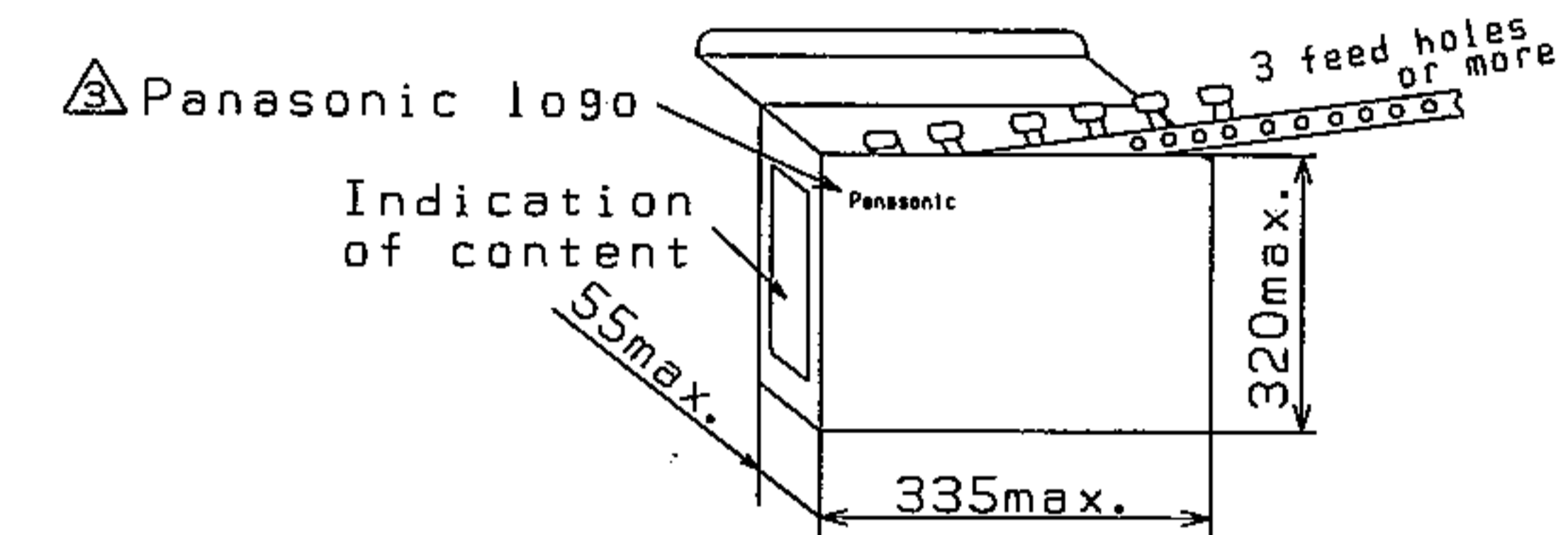

2. packing quantity

Capacitance range (μF)	Quantity (pcs.)
0.01~0.39	2000
0.47~1.0	1000

Handling notes

- 1) One package must be packed one product only.
- 2) The storage must be stacked 5 boxes or less (surface printed placing upward) (For prevention from displacement of capacitors and damage of lead crimping)
- 3) The packing box must be handled with care and never thrown out.
- 4) The bamboo bars are removed for use. (824~105)

Reference

TYPE NAME
 ECQV 1J***JM3
 DRAWING No.
 CV-H-B46B(2/2)

Panasonic Electronic Devices Co.,Ltd.
 Capacitor Business Unit.
 Panasonic Electronic Devices Matsue Co.,Ltd.